

Steps

SP0003

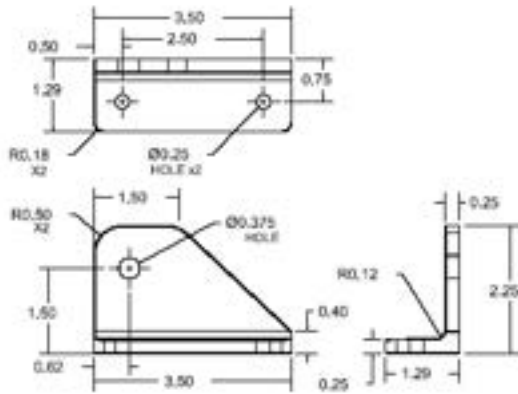

SP0003

Lefthand Step Bracket

1) Finish: ball-burnished.



SP0004

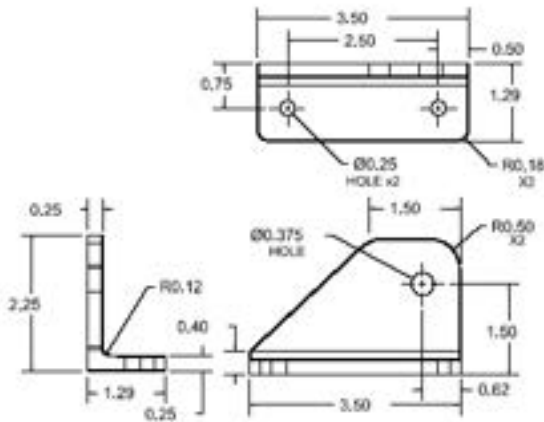

SP0004

Righthand Step Bracket

1) Finish: ball-burnished.



SP2001

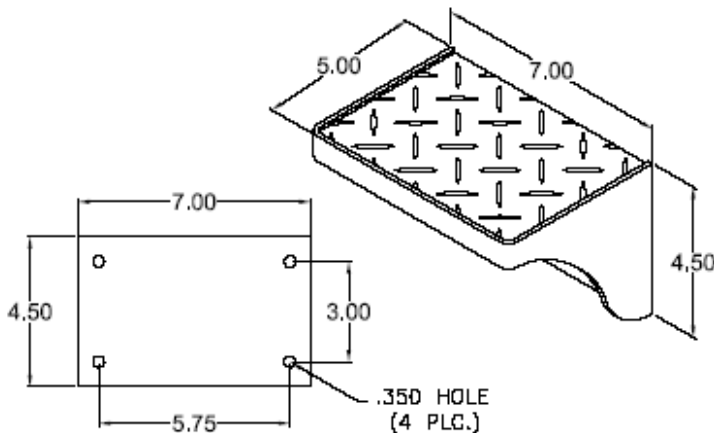

SP2001
Surface Mount
Step

1) Finish: All outside surfaces are polished. Inside is bead-blasted.

SP2002

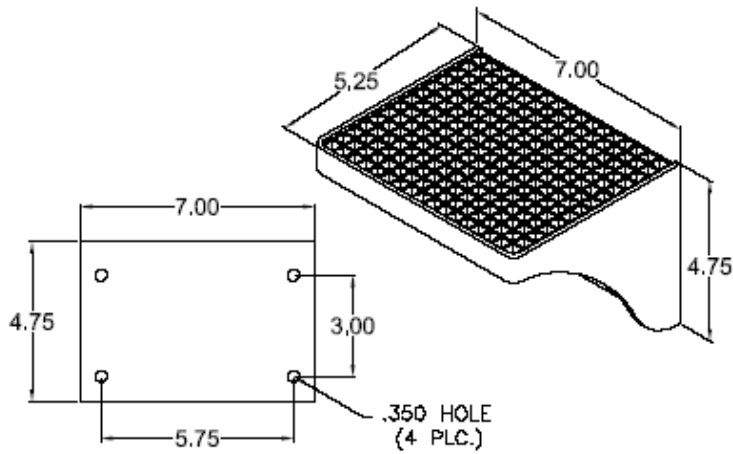

SP2002

Surface Mount Step with Pyramid Tread

1) Finish: All outside surfaces are polished. Inside is bead-blasted.

SP2003

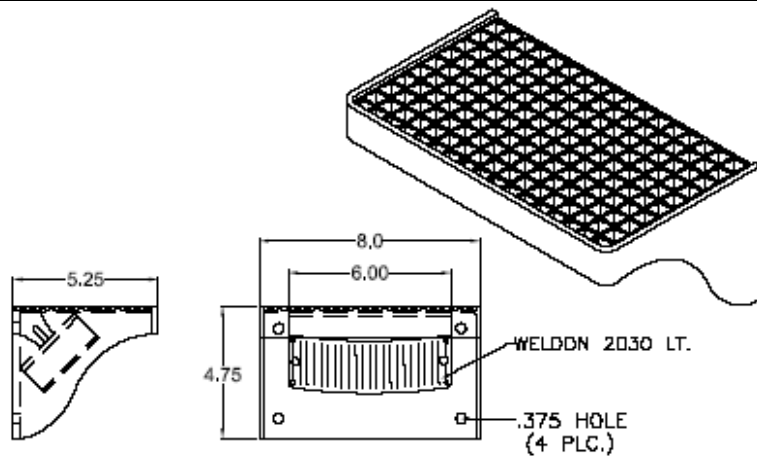

SP2003

Surface Mount Step with Pyramid Tread

1) Finish: All outside surfaces are polished. Inside is bead-blasted.
2) Designed to use a Weldon 2030 clear light mounted at a 45° angle (optional).

SP2003-B

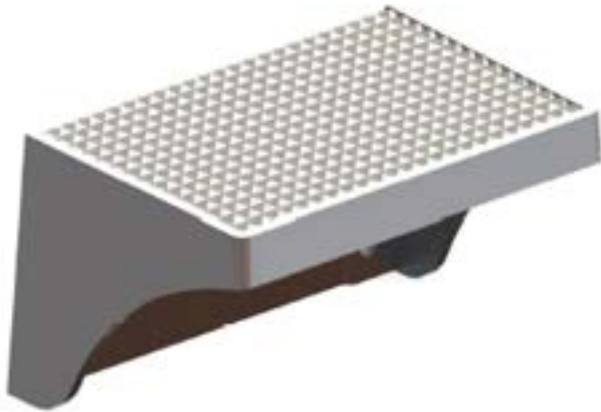

- 1) Finish: Exterior surfaces are polished. Inside is ball-burnished.
- 2) Supplied w/ LED light (WL0501 type), SP0007 adapter casting for LED, and mounting screws.

SP2003-B

Surface Mount Step (5-1/4" x 8", Pyramid) w/ LED Light



SP2004

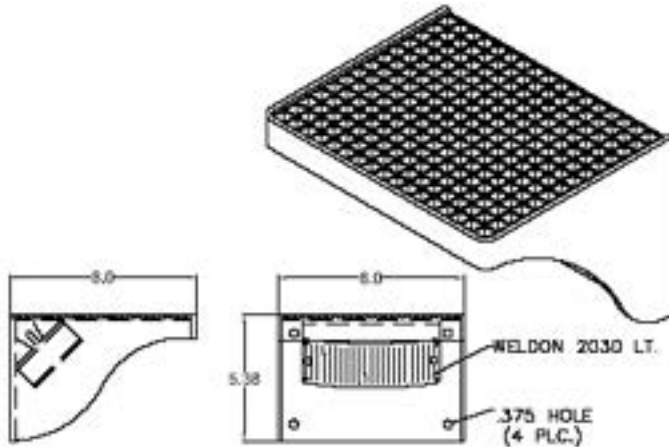

SP2004

Surface Mount Step w/ Light with Pyramid Tread

- 1) Finish: All outside surfaces are polished. Inside is bead-blasted.
- 2) Designed to use a Weldon 2030 clear light mounted at a 45° angle (optional).
- 3) Designed to meet new **1901-20 Specs.**

SP2004-D



SP2004-D Surface Mount Step (8"x 8", Pyramid) w/ LED Light

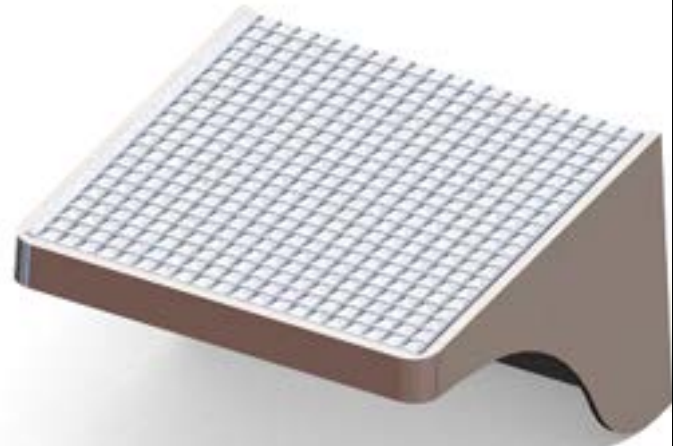

- 1) Finish: Exterior surfaces are polished.
Inside is ball-burnished
- 2) Supplied w/ LED light (WL0501 type),
SP0007 adapter casting for LED,
and mounting screws.

SP2004-TB



SP2004-TB Surface Mount Step (8"x 8", Pyramid w/ through holes) w/ LED Light

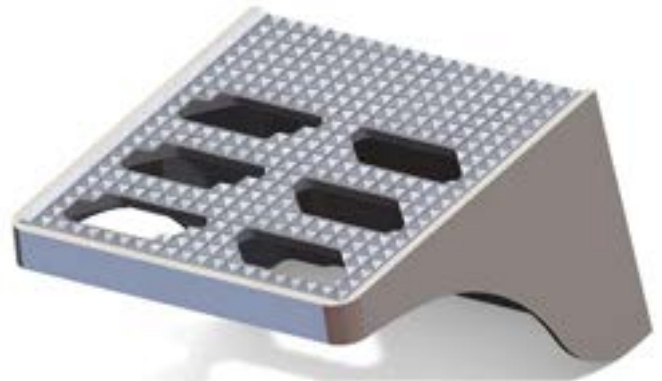

- 1) Finish: Exterior surfaces are polished.
Inside is ball-burnished
- 2) Supplied w/ LED light (WL0501 type),
SP0007 adapter casting for LED,
and mounting screws.

SP2006

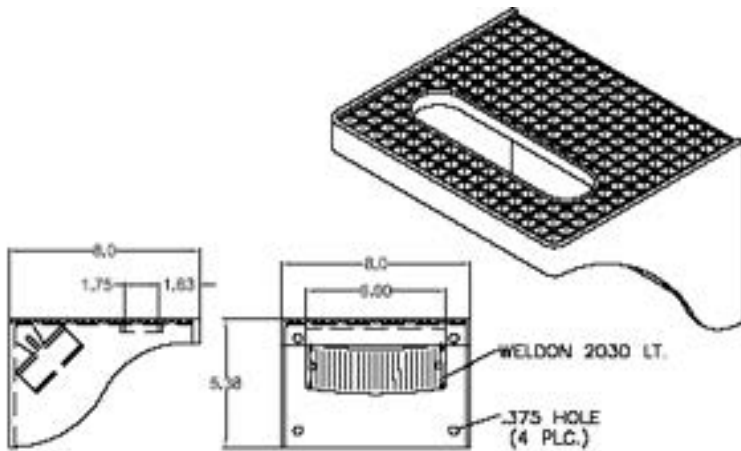

SP2006

Surface Mount Step w/ Light with Pyramid Tread & Handhold

- 1) Finish: All outside surfaces are polished. Inside is bead-blasted.
- 2) Designed to use a Weldon 2030 clear light mounted at a 45° angle (optional).
- 3) Designed to meet new 1901-20 Specs.

SP2006-B



SP2006-B

Surface Mount Step (8" x 8", Pyramid w/ Handhold) w/ LED Light

- 1) Finish: Exterior surfaces are polished. Inside is ball-burnished
- 2) Supplied w/ LED light (WL0501 type), SP0007 adapter casting for LED, and mounting screws.



SP2007

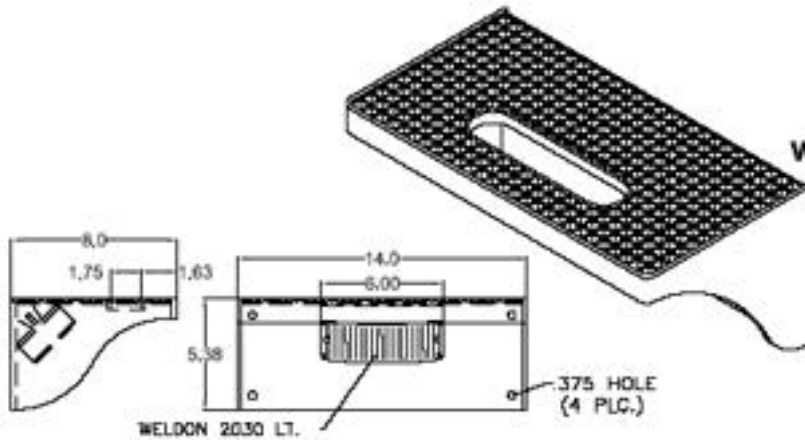

SP2007

Surface Mount Step w/ Light with Pyramid Tread & Handhold

- 1) Finish: All outside surfaces are polished. Inside is bead-blasted.
- 2) Designed to use a Weldon 2030 clear light mounted at a 45° angle (optional).
- 3) Designed to meet new 1901-20 Specs.

SP2007-B



SP2007-B

Surface Mount Step (8" x 14", Pyramid w/ Handhold) w/ LED Light

- 1) Finish: Exterior surfaces are polished. Inside is ball-burnished
- 2) Supplied w/ LED light (WL0501 type), SP0007 adapter casting for LED, and mounting screws.

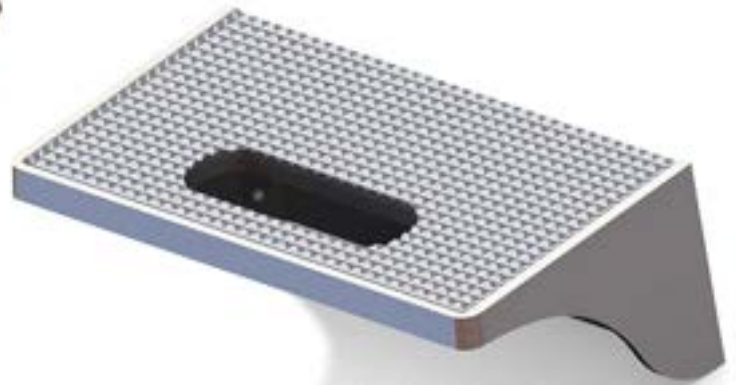

SP2008

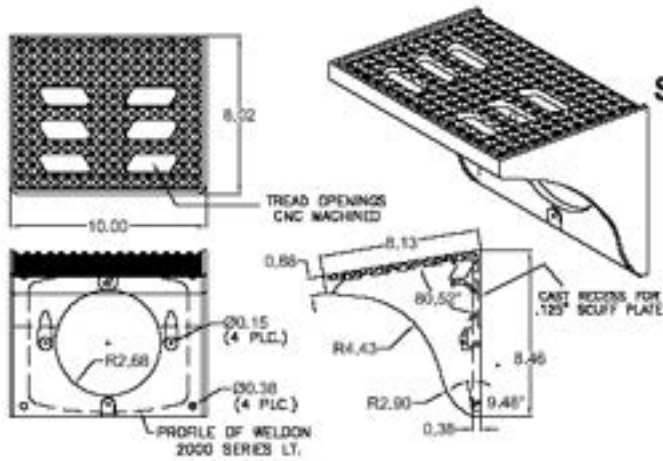

SP2008

Surface Mount Step w/ Light with Pyramid Tread

- 1) Finish: All outside surfaces are polished. Inside is bead-blasted.
- 2) Designed to use a Weldon 2000 Series light mounted at a 0° angle (vehicle body is mounted at a 9.48° angle).
- 3) Polished scuff plate available.

SP2009

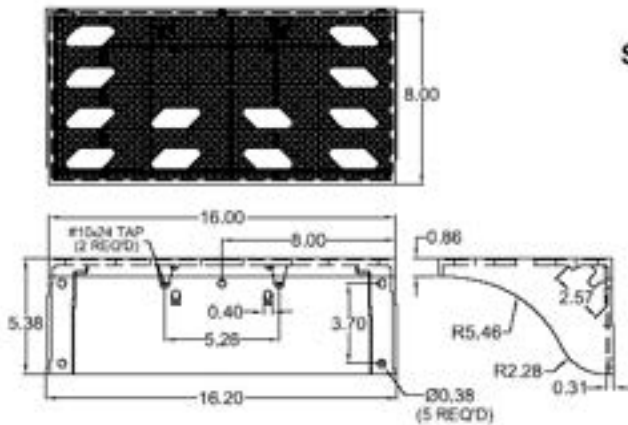

SP2009

Surface Mount Step w/ Light with Pyramid Tread

- 1) Finish: All outside surfaces are polished. Inside is bead-blasted.
- 2) Designed to use a Weldon 2030 Series light mounted at a 45° angle (optional).



SP2009-B

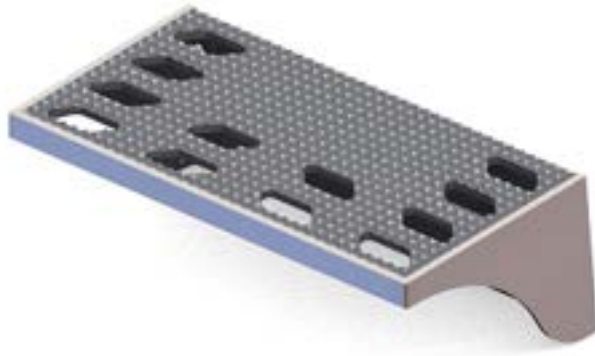

SP2009-B Surface Mount Step (8" x 16", Pyramid w/ through holes) w/ LED Light

- 1) Finish: Exterior surfaces are polished. Inside is ball-burnished
- 2) Supplied w/ LED light (WL0501 type), SP0007 adapter casting for LED, and mounting screws.



SP2010

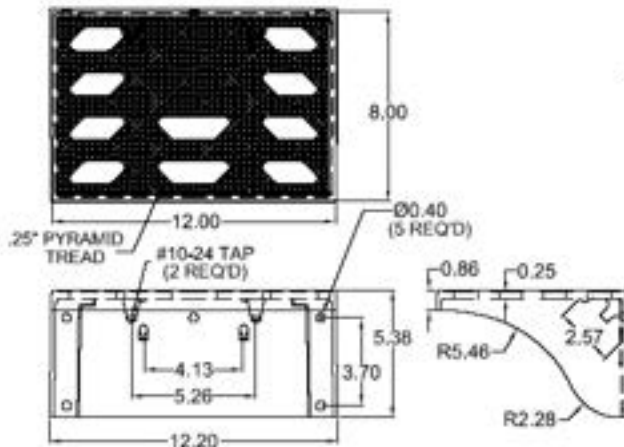

SP2010 Surface Mount Step w/ Light with Pyramid Tread

- 1) Finish: All outside surfaces are polished. Inside is bead-blasted.
- 2) Designed to use a Weldon 2030 Series light mounted at a 45° angle (optional).



SP2010-B

SP2010-B
Surface Mount Step
(8"x 12", Pyramid w/ through holes)
w/ LED Light

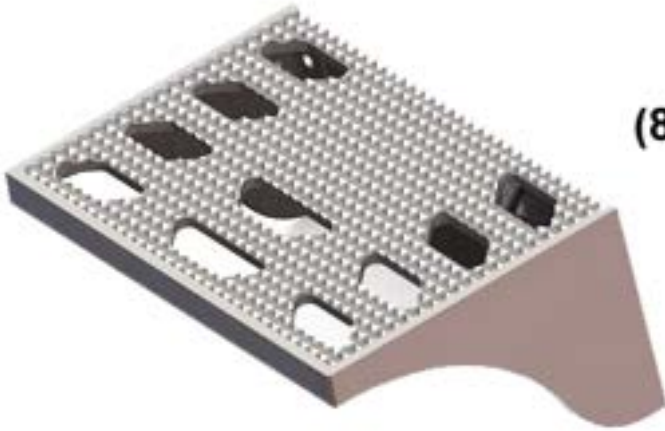

- 1) Finish: Exterior surfaces are polished. Inside is ball-burnished
- 2) Supplied w/ LED light (WL0501 type), SP0007 adapter casting for LED, and mounting screws.



SP2011

SP2011
Surface Mount Step w/ Light
with Raised Tread & Handhold

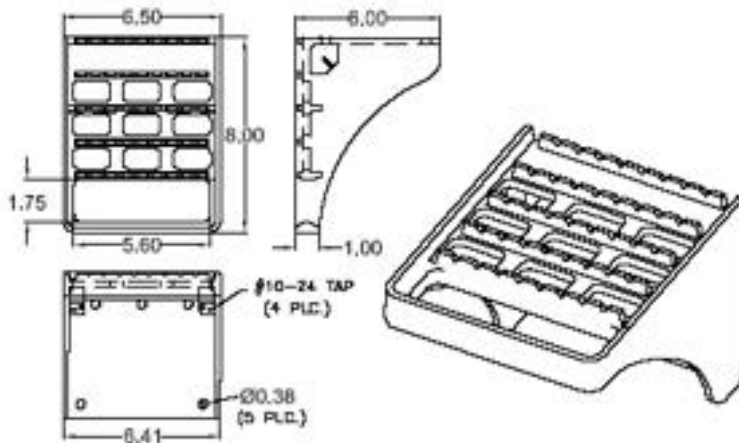

- 1) Finish: All outside surfaces are polished.
- 2) Designed to mount a Weldon 2030 clear light mounted at a 45° angle (optional).
- 3) Designed to meet new 1901-20 specs.
- 4) Raised "Open" tread design.

SP2011-C



SP2011-C

Surface Mount Step
(6-1/2" x 8", Raised w/ Handhold)
w/ LED Light



- 1) Finish: Exterior surfaces are polished. Inside is ball-burnished
- 2) Supplied w/ LED light (WL0501 type), SP0007 adapter casting for LED, and mounting screws.

SP2012

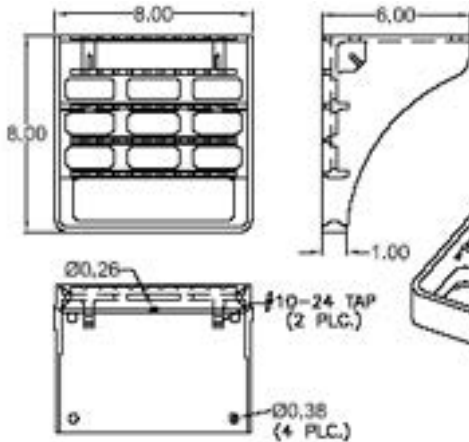

SP2012

Surface Mount Step w/ Light
with Raised Tread & Handhold

- 1) Finish: All outside surfaces are polished.
- 2) Designed to mount a Weldon 2030 clear light mounted at a 45° angle (optional).
- 3) Designed to meet new 1901-20 specs.
- 4) Raised "Open" tread design.

SP2012-D

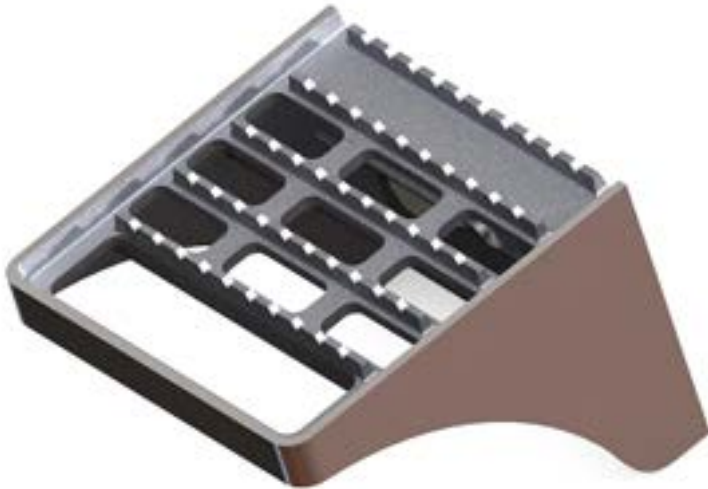

SP2012-D

Surface Mount Step
(8" x 8", Raised w/ Handhold)
w/ LED Light



- 1) Finish: Exterior surfaces are polished. Inside is ball-burnished
- 2) Supplied w/ LED light (WL0501 type), SP0007 adapter casting for LED, and mounting screws.

SP2013

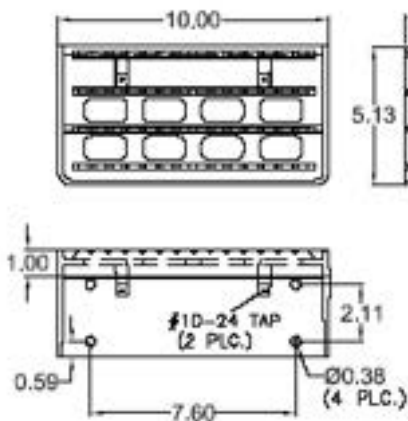

SP2013

Surface Mount Step w/ Light
with Raised Tread

- 1) Finish: All outside surfaces are polished.
- 2) Designed to mount a Weldon 2030 clear light mounted at a 45° angle (optional).
- 3) Raised "Open" tread design.

SP2013-B



SP2013-B

Surface Mount Step
(5-1/8" x 10", Raised)
w/ LED Light



- 1) Finish: Exterior surfaces are polished. Inside is ball-burnished
- 2) Supplied w/ LED light (WL0501 type), SP0007 adapter casting for LED, and mounting screws.

SP2014

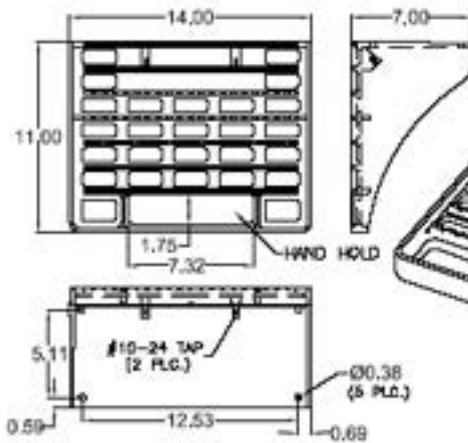

SP2014

Surface Mount Step w/ Light
with Raised Tread & Handhold

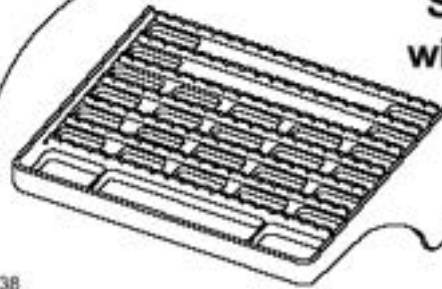

- 1) Finish: All outside surfaces are polished.
- 2) Designed to mount a Weldon 2030 clear light mounted at a 45° angle (optional).
- 3) Designed to meet new 1901-20 specs.
- 4) Raised "Open" tread design.

SP2014-B



SP2014-B

Surface Mount Step
(11" x 14", Raised w/ Handhold)
w/ LED Light



- 1) Finish: Exterior surfaces are polished. Inside is ball-burnished
- 2) Supplied w/ LED light (WL0501 type), SP0007 adapter casting for LED, and mounting screws.

SP2016

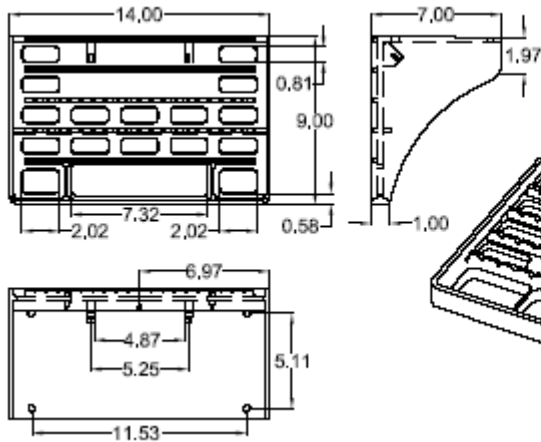

SP2016

Surface Mount Step w/ Light with Raised Tread & Handhold

- 1) Finish: All outside surfaces are polished.
- 2) Designed to use a Weldon 2030 clear light mounted at a 45° angle (optional).
- 3) Raised "Open" tread design.

SP2016-B



SP2016-B

**Surface Mount Step
(8" x 14", Raised w/ Handhold)
w/ LED Light**

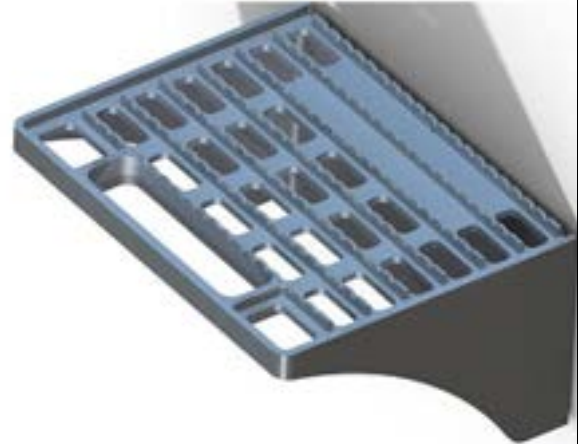

- 1) Finish: Exterior surfaces are polished. Inside is ball-burnished
- 2) Supplied w/ LED light (WL0501 type), SP0007 adapter casting for LED, and mounting screws.

SP2017

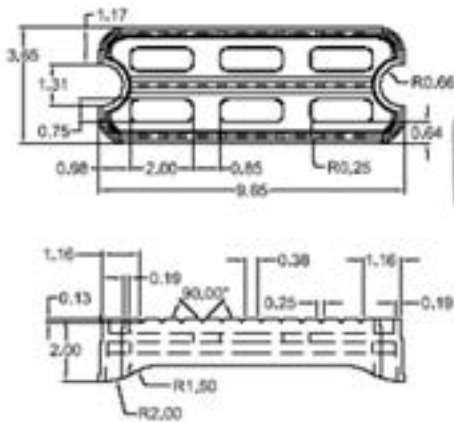

SP2017

Rear Ladder Step

- 1) Finish: All outside surfaces are polished.
- 2) Raised "Open" tread design.

SP2018

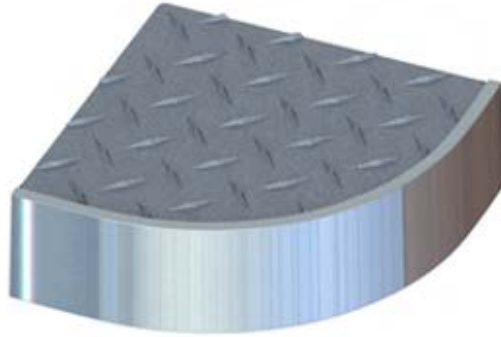
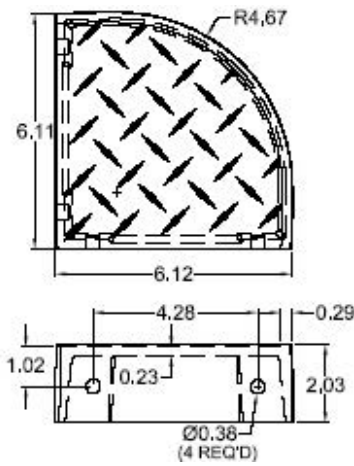

SP2018 Inside Corner Step

1) Finish: All outside surfaces are polished.

SP2023

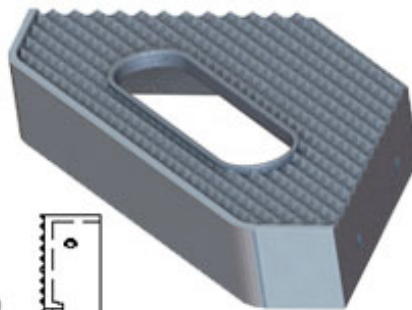
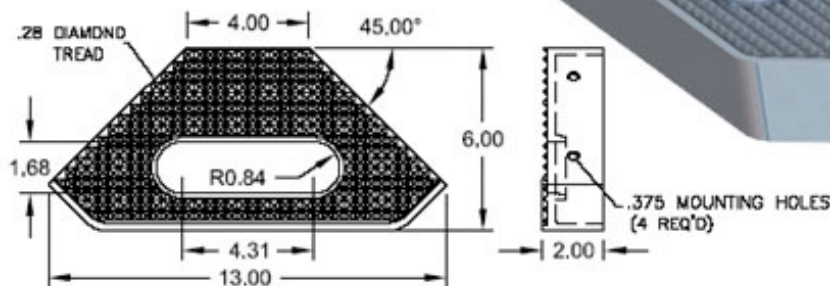

SP2023 Inside Corner Step with Hand-Hold

1) Finish: All outside surfaces are polished.

SP2024

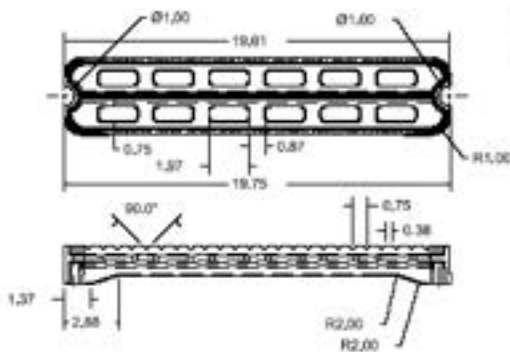

SP2024 Ladder Step w/ Raised Tread

1) Finish: ball-burnished

SP2025

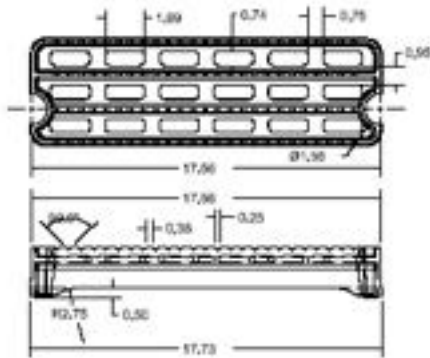

SP2025 Ladder Step w/ Raised Tread

1) Finish: wheel-a-brated

SP2026

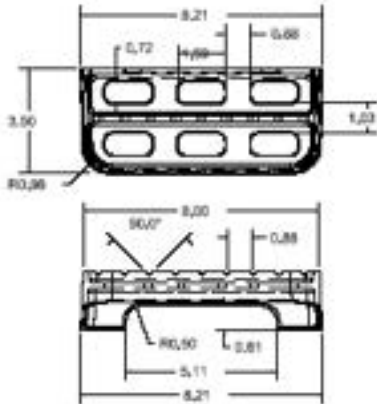

SP2026 Wheel Well Step w/ Raised Tread

1) Finish: ball-burnished

SP2027

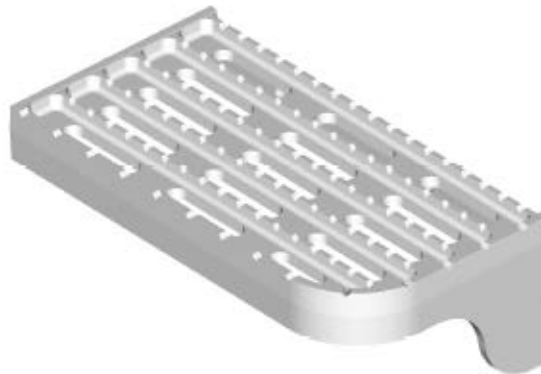
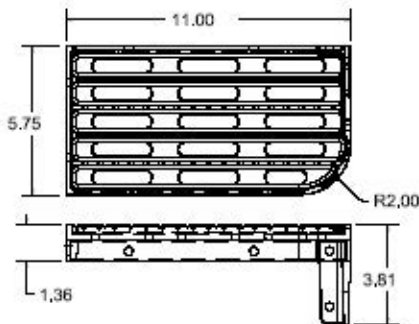

SP2027 Left Inside Corner Step

1) Finish: outside
surfaces are
polished.

SP2028

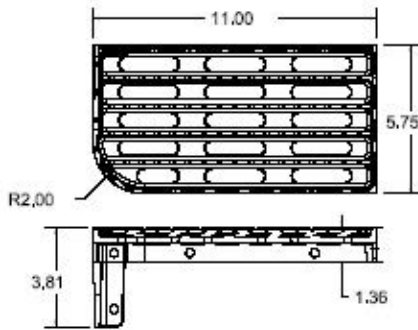

SP2028 Right Inside Corner Step

1) Finish: outside surfaces are polished.

SP2029

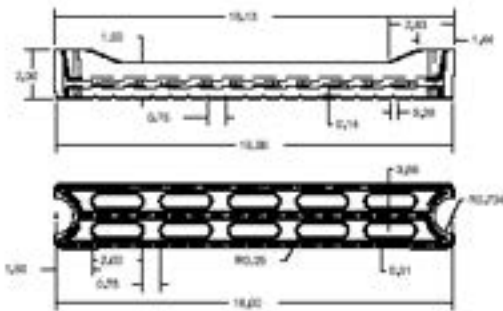

SP2029 Ladder Step w/ Raised Tread

1) Finish: ball-burnished

SP2030

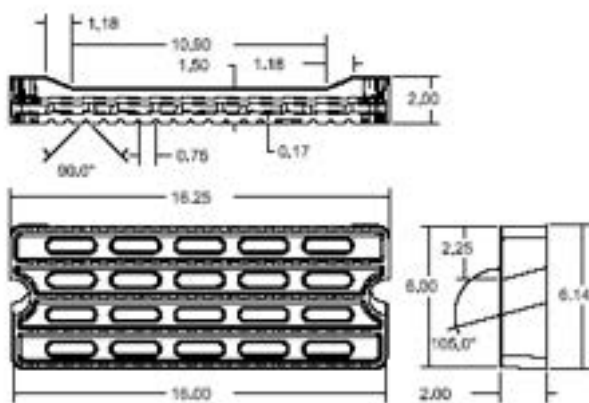

SP2030 Ladder Step w/ Raised Tread

1) Finish: ball-burnished

SP2032

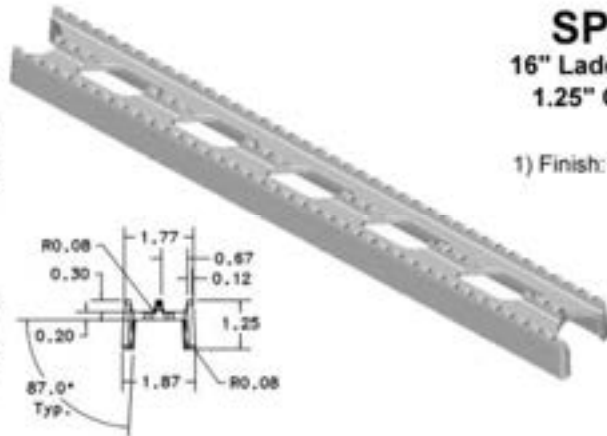
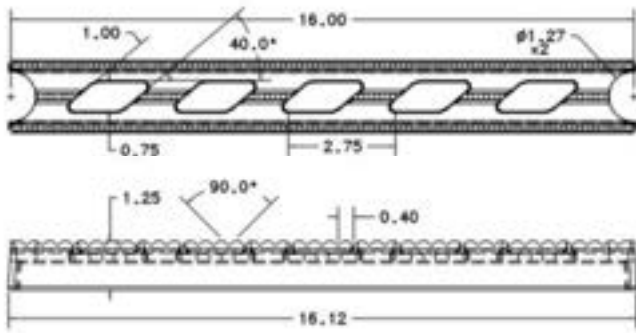

SP2032

16" Ladder Step for
1.25" OD tubing

1) Finish: ball-burnished.

SP2033

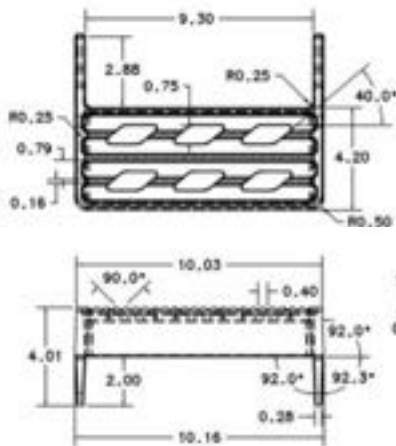

SP2033

10" Tank Step -
Rear R33"

1) Finish: ball-burnished.

SP2034

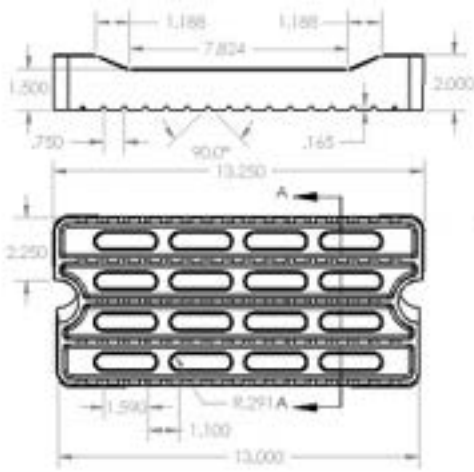

SP2034-1 13" Ladder Step w/ Raised Tread. 15d. Angle

1)Finish: Ball-burnished w/ sides
and end polished



SP2035

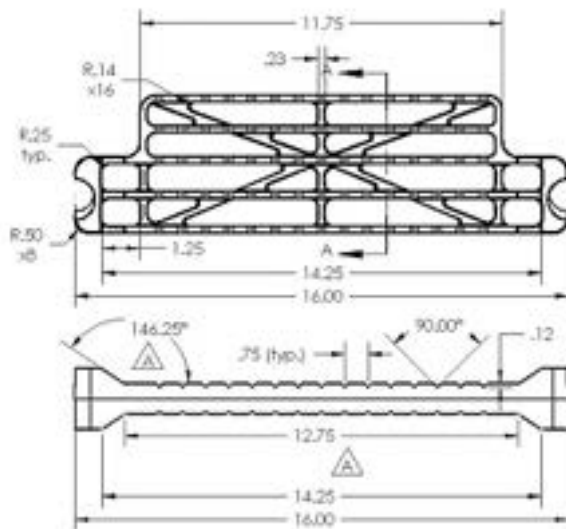

SP2035-5 16" Ladder Step

1)Finish: Ball-burnished w/ sides
and end polished

SP2036

SP2036-5 15" x 2.0" Ladder Step

- 1) Finish: Ball-burnished.
- 2) For bolting to 2" wide extrusion or welding underneath

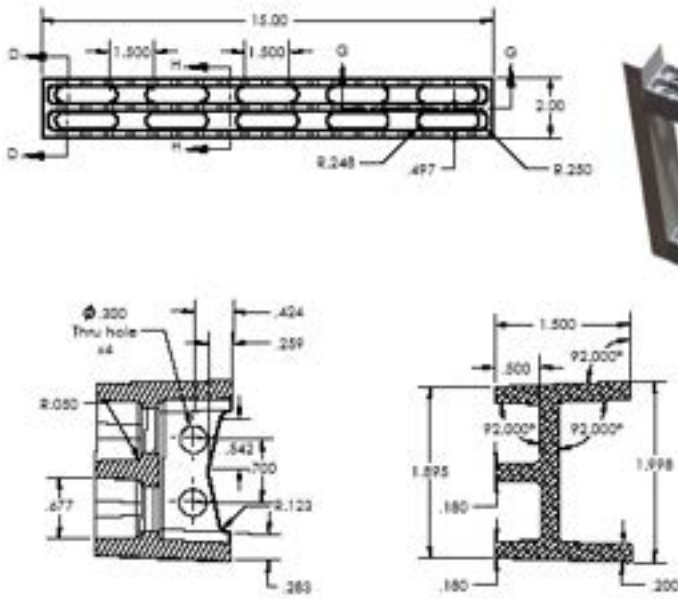

SP2037

SP2037-1 8" x 8" Surface Mount Step (LED Light Capable)

- 1) Finish: Ball-burnished casting w/ polished front band and sides
- 2) For use as a single step or w/ two AH0225 LED Lids for upper and lower illumination
- 3) Cast in hand-hold

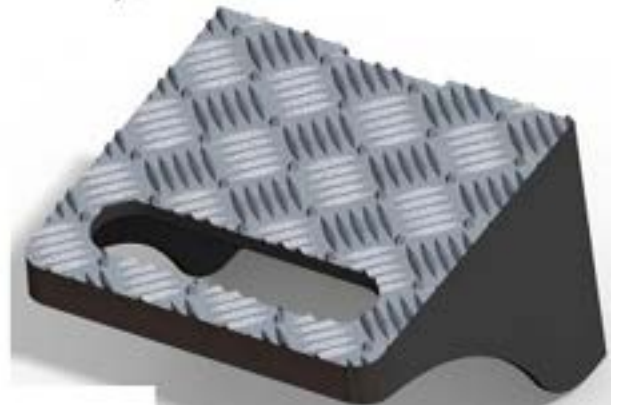
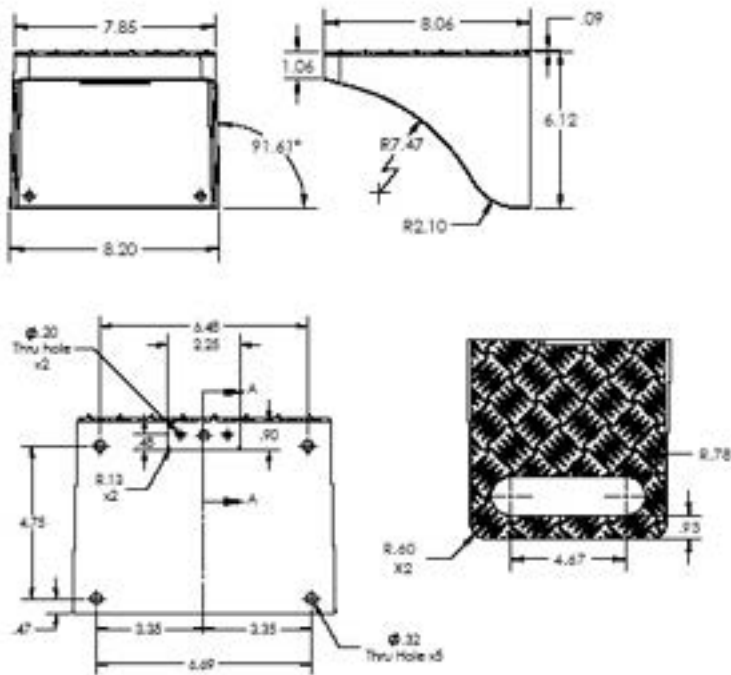

SP2038

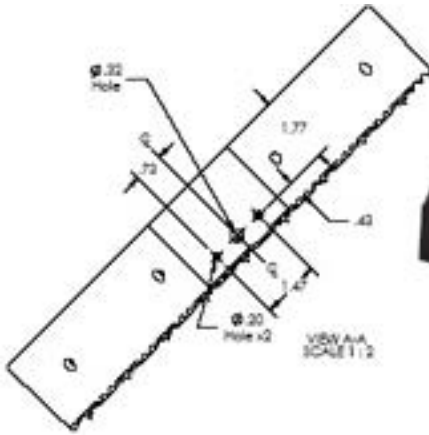

SP2038-1 45d. Angle Surface Mount Step (LED Light Capable)

- 1) Finish: Ball-burnished casting w/ polished front band and sides
- 2) For use as a single step or w/ two AH0225 LED Lids for upper and lower illumination
- 3) Cast in hand-hold

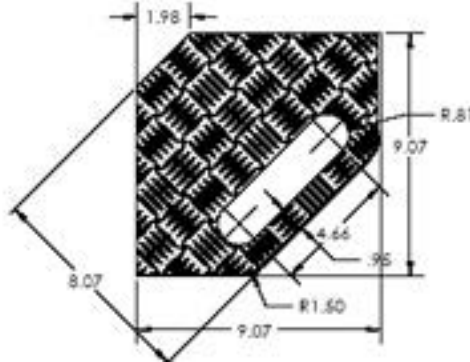
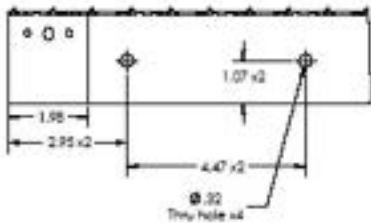

SP2041

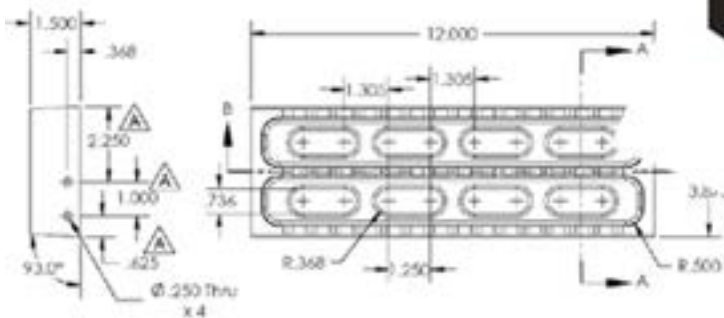
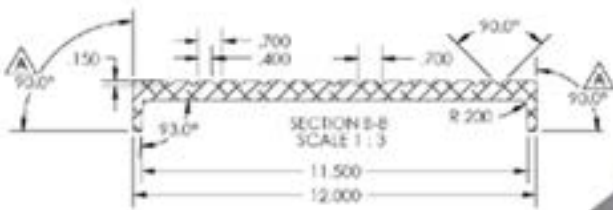

SP2041-5 12.00" x 3.875" Ladder Step

- 1) Finish: Ball-burnished.
- 2) For bolting or welding underneath



SP2042

SP2042-5 15.00" x 3.875" Ladder Step

- 1) Finish: Ball-burnished.
- 2) For bolting or welding underneath

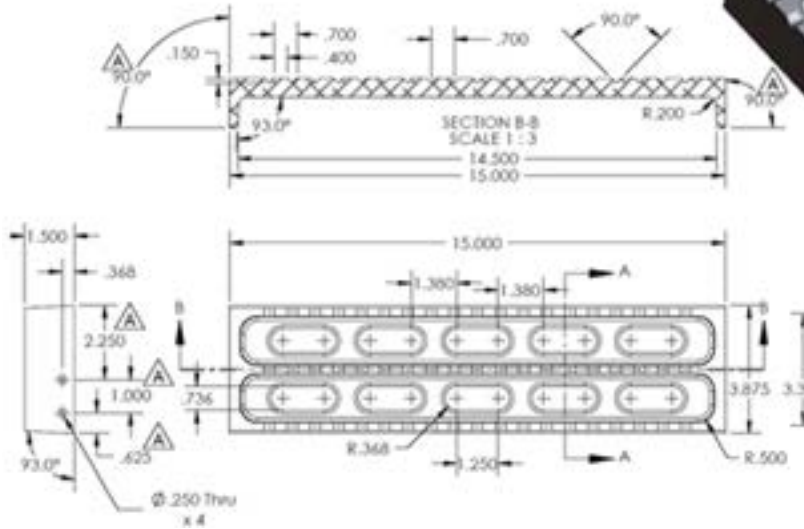

SP2043

SP2043-5 13.5" x 2.50" wide, Ladder Step w/ Raised Tread

- 1) Finish: Ball-burnished.
- 2) For bolting or welding underneath

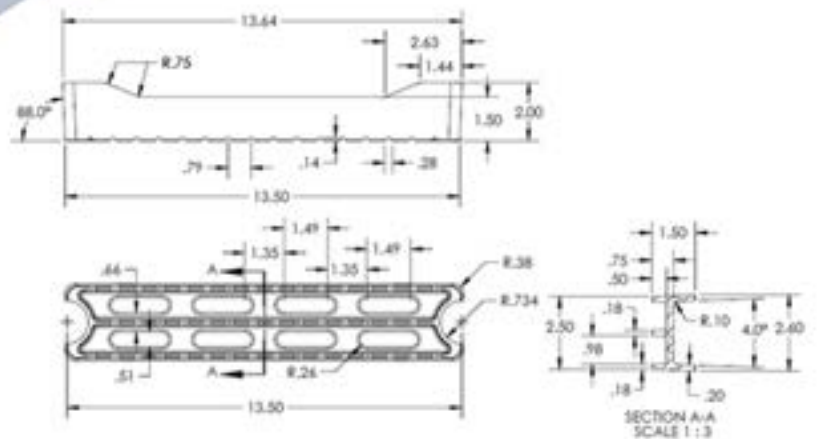

SP2701

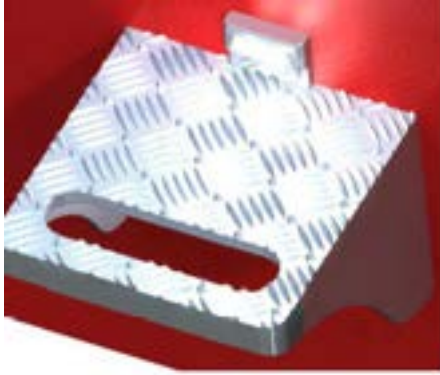

SP2701-1

8" x 8" Surface Mount Step w/ upper & lower LED lights (AH0225 - MKL375-3W w/ 22 gauge wire)

- 1) Finish: Ball-burnished casting w/ polished front band and sides
- 2) Uses two AH0225 LED Lids for upper and lower illumination
- 3) Cast in hand-hold
- 4) Shipped assembled

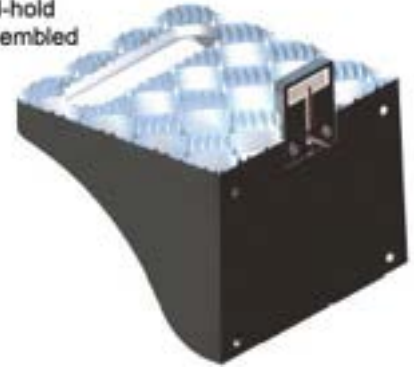
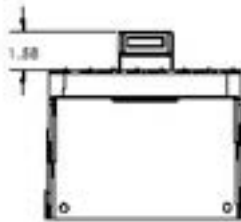
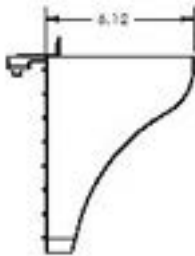
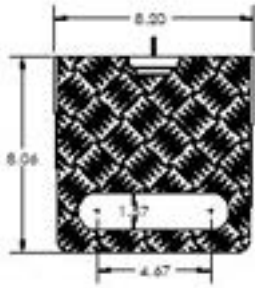

SP2702

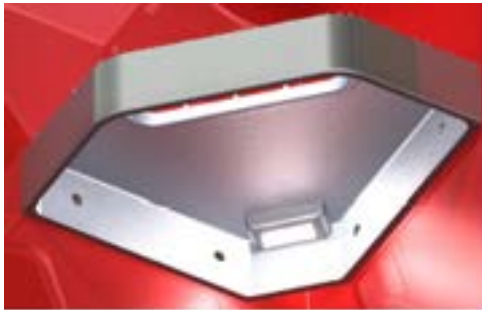

SP2702-1

45d. Angle Surface Mount Step w/ upper & lower LED lights (AH0225 - MKL375-3W w/ 22 gauge wire)

- 1) Finish: Ball-burnished casting w/ polished front band and sides
- 2) Uses two AH0225 LED Lids for upper and lower illumination
- 3) Cast in hand-hold
- 4) Shipped assembled

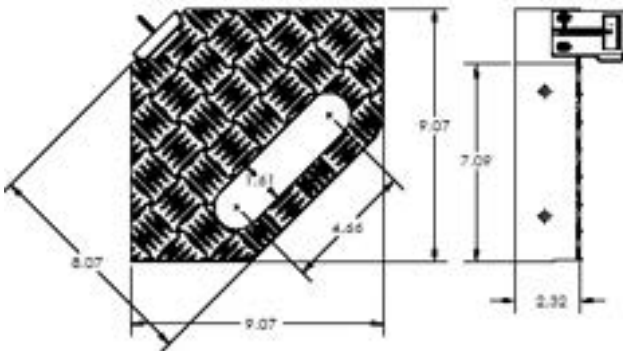

SP2901

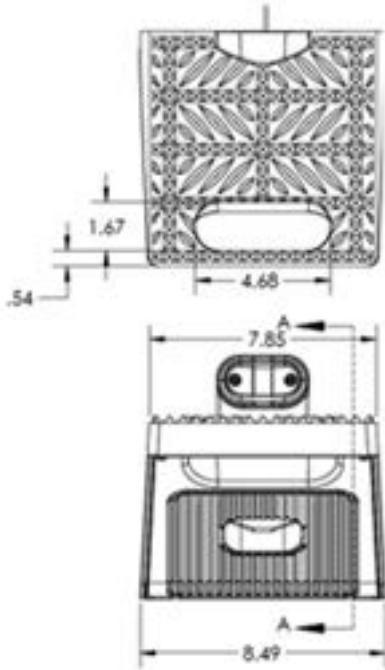

1. 8" x 8" Surface Mount Step, w/ Cover Lid, w/ upper/lower LED lights (WL0501-C Clear LED x2).
2. Finish: Tread is ball-burnished, exterior surfaces on step casting, lid face and upper LED light mount are polished.

SP2901
8" x 8" Surface Mount Step,
w/ Cover Lid, w/
upper/lower LED lights
(WL0501-C Clear LED x2)

