

# Fuel Filler Guards

## FG0001

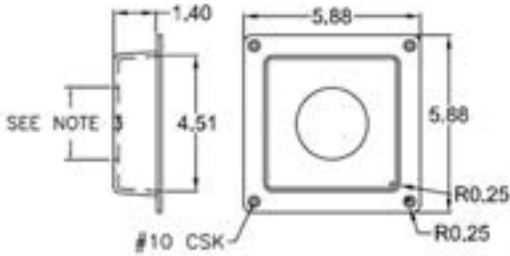

## FG0001 Gas Fill Guard 0° Angle

- 1) Finish: Flange is polished. Inside is bead-blasted.
- 2) Angle: 0°
- 3) Customer please specify when ordering: 2 1/4", 2 1/2", 2 5/8" hole diameter size.

## FG0002-A

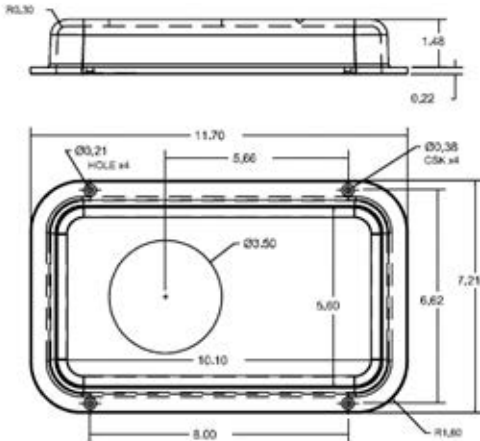

## FG0002-A Water Inlet Panel Recessed Box

- 1) Finish: Ball-burnished.
- 2) Angle: 0°
- 3) Single 3 1/2" hole.

## FG0002-B

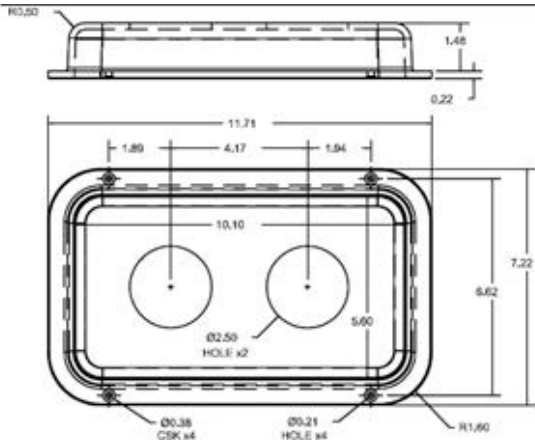

## FG0002-B Shore Power Panel Recessed Box

- 1) Finish: Ball-burnished.
- 2) Angle: 0°
- 3) Dual 2 1/2" holes.

**FG0003**

**FG0003-5  
Recessed Shoreline Box**

1) Finish: Ball-burnished.

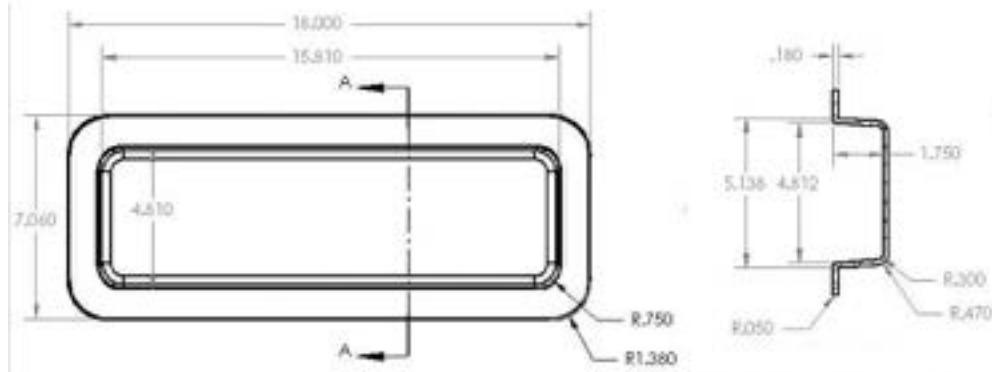

# FG0006-2\_Cyl\_Lock

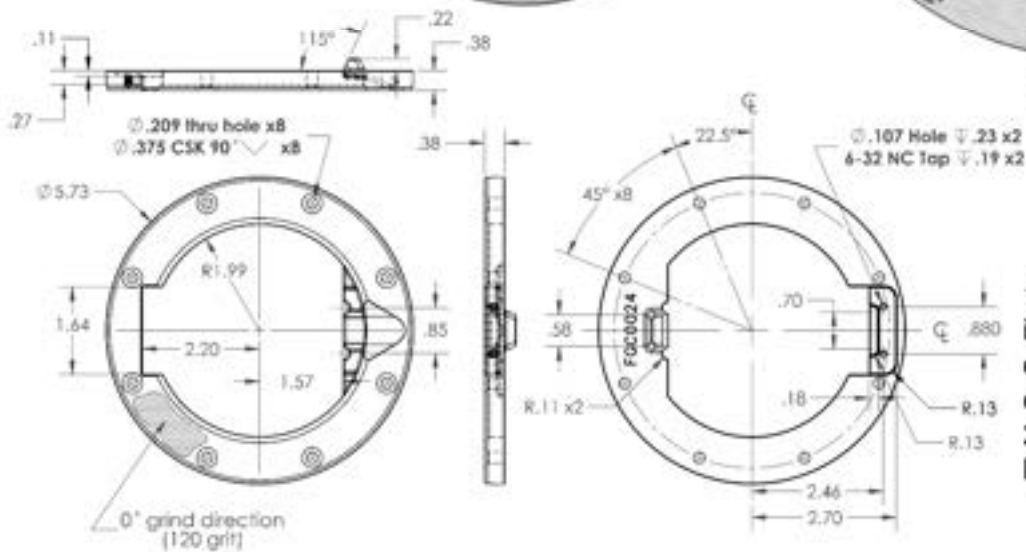
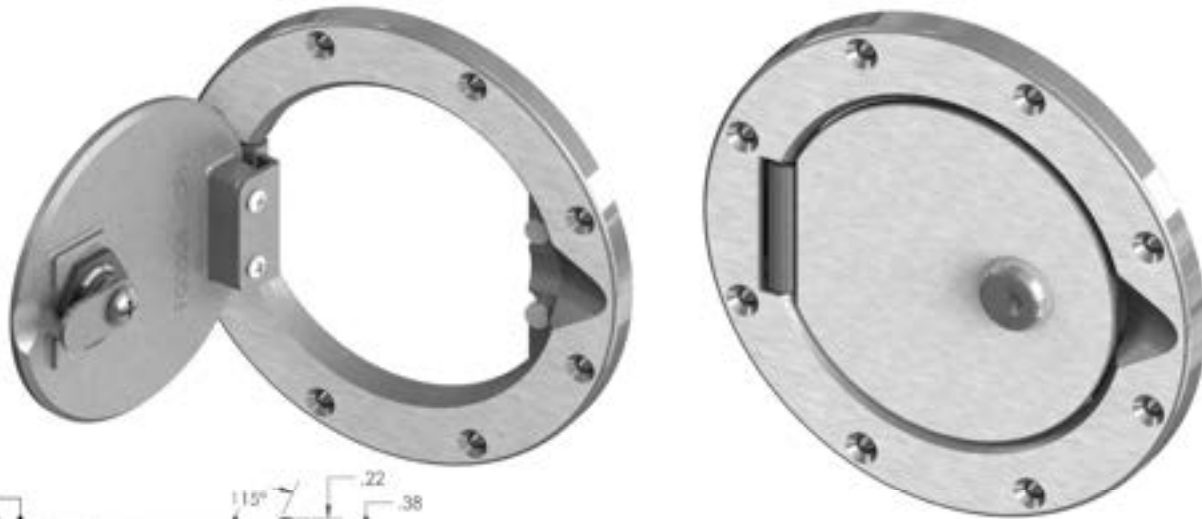

## FG0006-2\_Cyl\_Lock Fuel Filler Door Assembly, Keyed Cylinder Lock

1. Finish: ball-burnished interior with 120 grit directional grind on face (0 d.) and outside edge.
2. With Keyed Cylinder Lock

# FG0006-2\_Friction

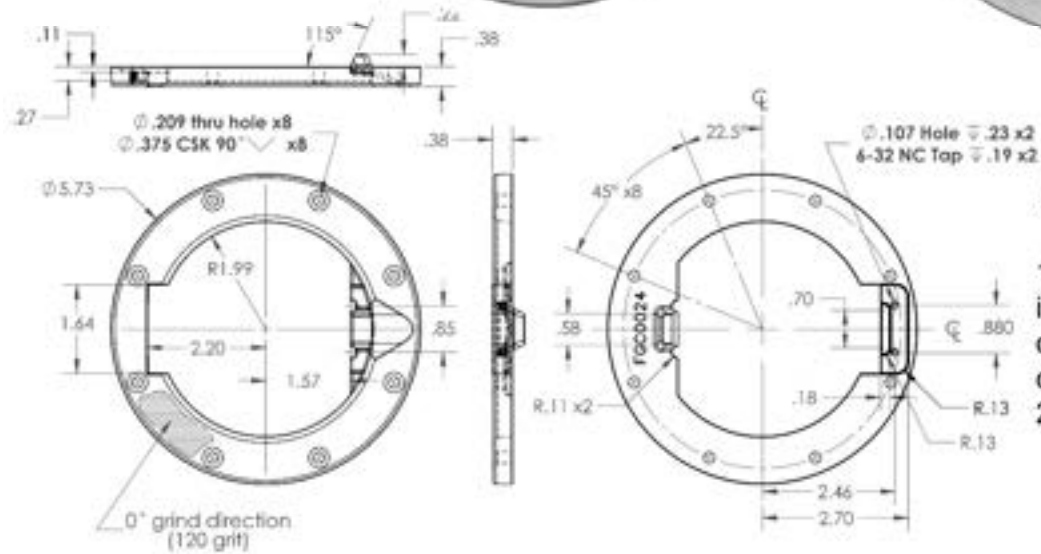

## FG0006-2\_Friction Fuel Filler Door Assembly, Roller Detent

1. Finish: ball-burnished interior with 120 grit directional grind on face (0 d.) and outside edge.
2. With Roller Detent.

## FG0501

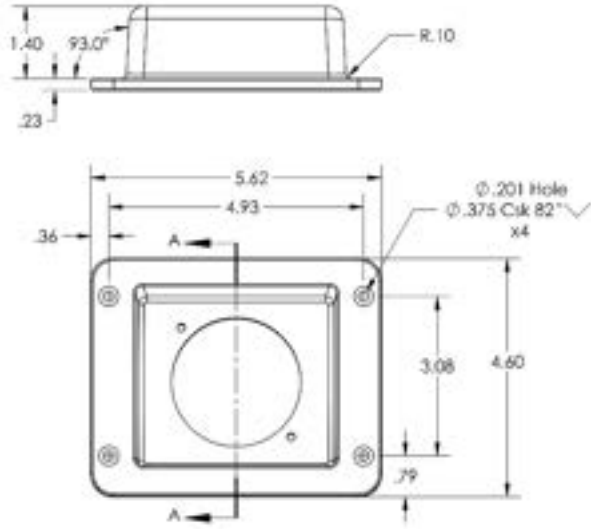

## FG0501

5.62d. Fuel Filler Guard w/ 2.5" Hole & .1563" Holes x2

1. Finish: (-1) Polished flange w/ interior wheel-a-brated.

## FG0901

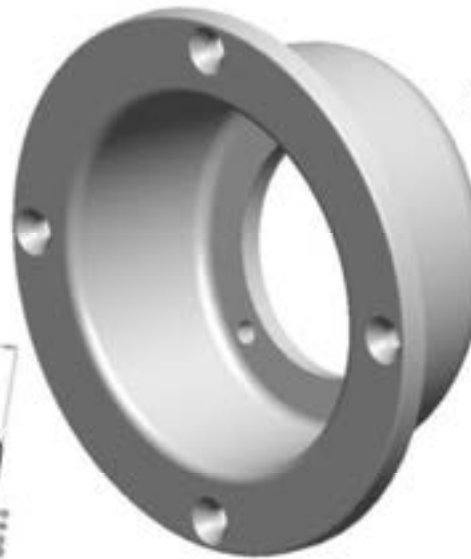
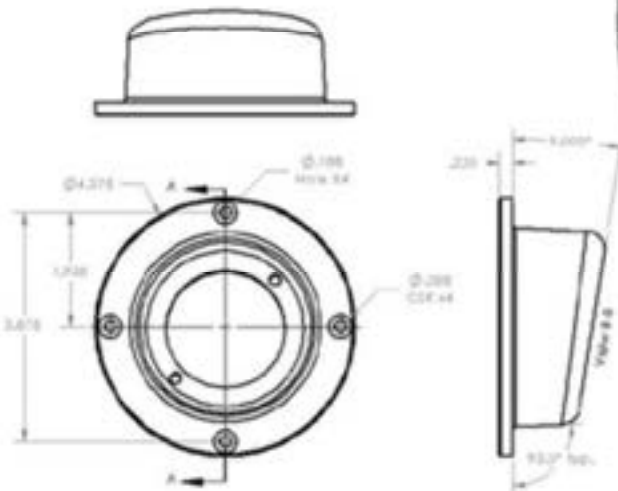

## FG0901

9d. Fuel Filler Guard

- 1) Finish: Exterior flange is polished. Interior is wheel-a-brated.
- 2) Angle: 9 degree.
- 3) Rear hole is 2.00".

## FG1501

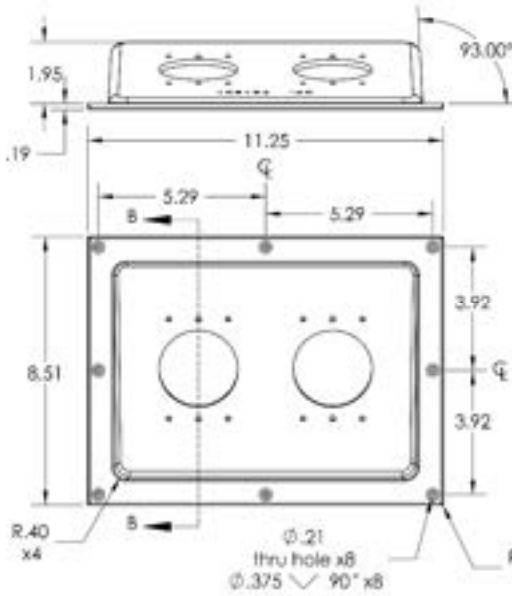

## FG1501 Shoreline Pocket Casting

1) Finish: interior is ball-burnished with flange surface and edges polished.



## FG1801

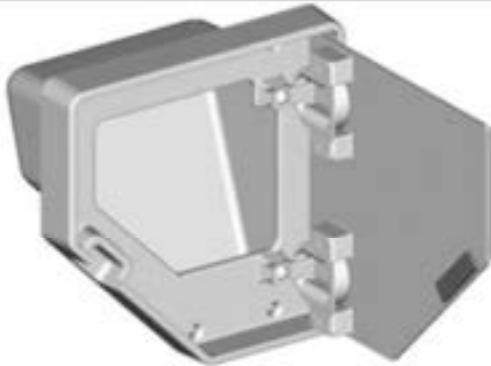

## FG1801 18.5d. Fuel Filler Guard with Lid

1) Finish: Exterior flange is polished. Interior is wheel-a-brated. Lid is 120 grit directional ground.  
2) Angle: 18.5 degree.  
3) Rear hole is 2.50".

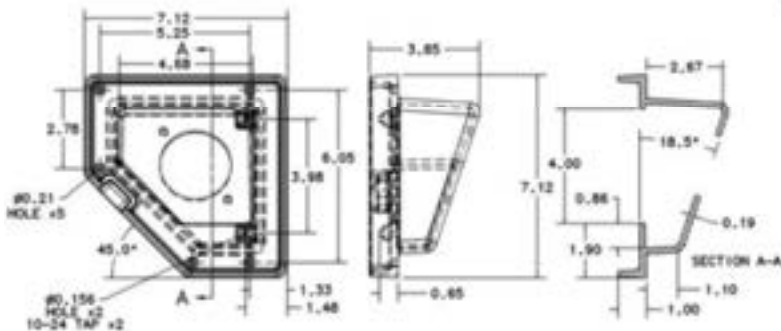

## FG2001

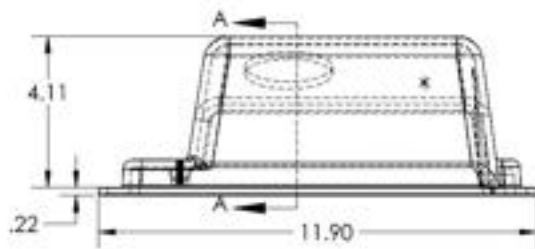

### FG2001 20d Fuel Filler Guard, Hinges Left

1) Finish: VFM for painting.

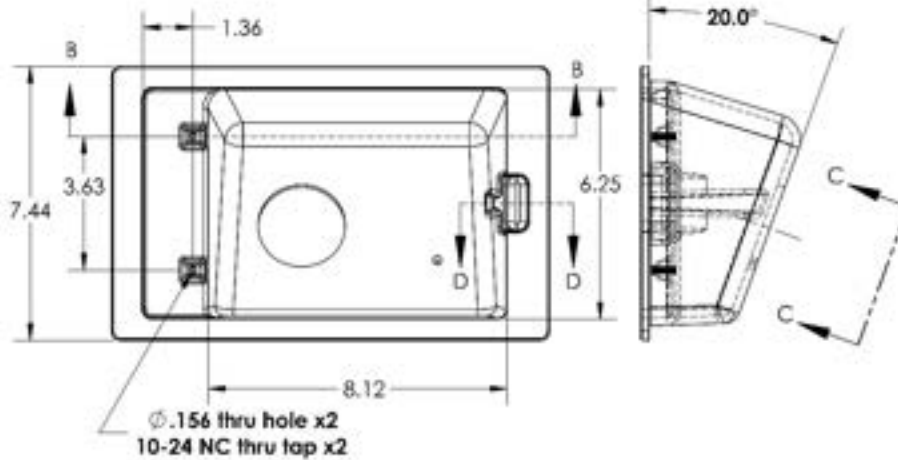

## FG2101

### FG2101 Gas Fill Guard 21° Angle

- 1) Finish: Flange is polished. Inside is bead-blasted.
- 2) Angle: 21°
- 3) Customer please specify when ordering: 2 1/4", 2 1/2", 2 5/8" hole diameter size.

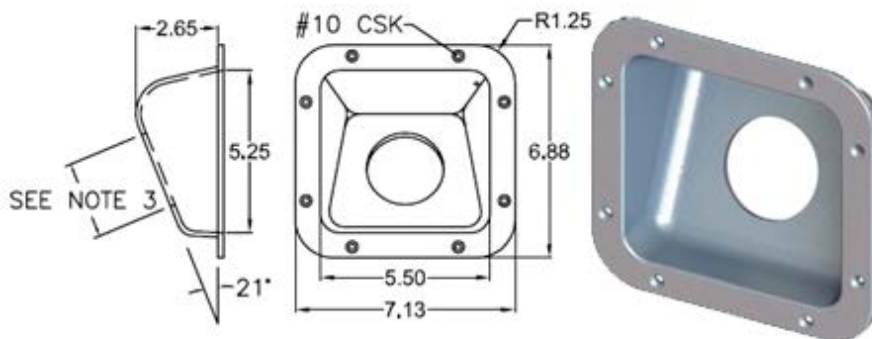

## FG2102

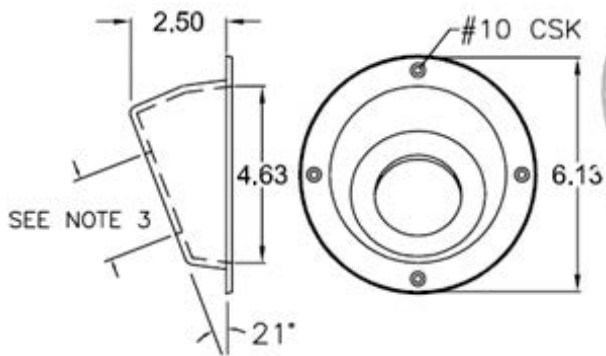

## FG2102 Gas Fill Guard 21° Angle

- 1) Finish: Flange is polished. Inside is bead-blasted.
- 2) Angle: 21°
- 3) Customer please specify when ordering: 2 1/4", 2 1/2", 2 5/8" hole diameter size.

## FG2103

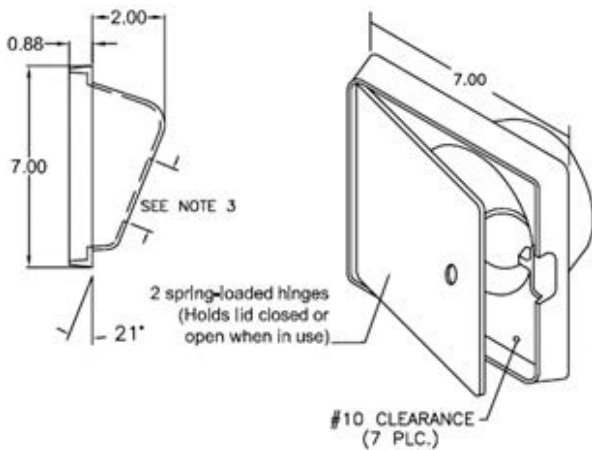

## FG2103 Gas Fill Guard with Lid 21° Angle

- 1) Finish: Flange is polished. Inside is bead-blasted. Lid is 120 grit directional ground.
- 2) Angle: 21°
- 3) Customer please specify when ordering: 2 1/4", 2 1/2", 2 5/8" hole diameter size.
- 4) All concealed hinges and mounting hardware.

## FG2104

1) Finish: Flange is polished, inside is ball-burnished

2) Part numbers & options:

FG2104-1-225 for 2.250" rear hole

FG2104-1-238 for 2.375" rear hole

FG2104-1-250 for 2.500" rear hole

FG2104-1-263 for 2.625" rear hole

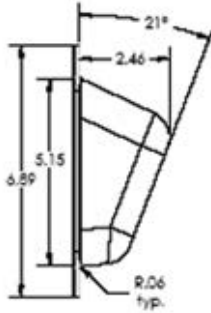
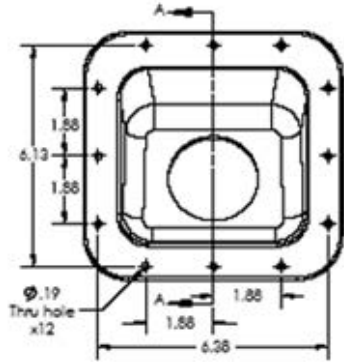
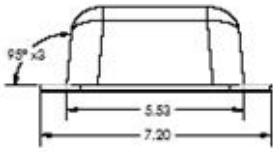

## FG2104 Gas Fill Guard 22° Angle

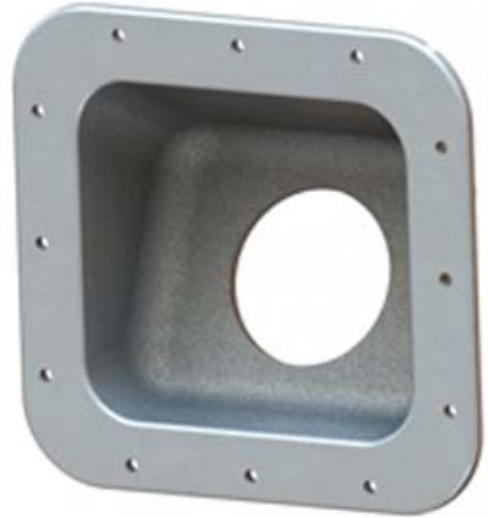

## FG2201

## FG2201

## Gas Fill Guard 22° Angle

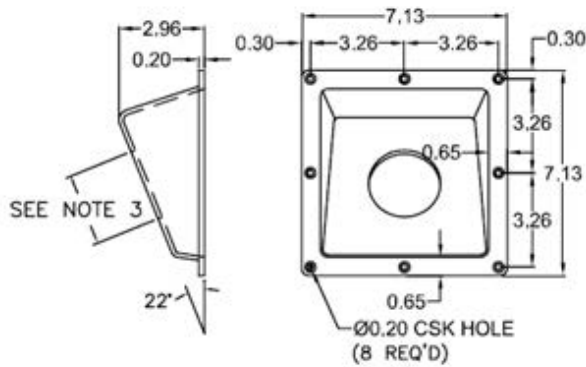

- 1) Finish: Flange is polished. Inside is bead-blasted.
- 2) Angle 22°
- 3) Customer please specify when ordering: 2 1/4", 2 1/2", 2 5/8" hole diameter size.

## FG2204

## FG2204 Gas Fill Guard 22° Angle

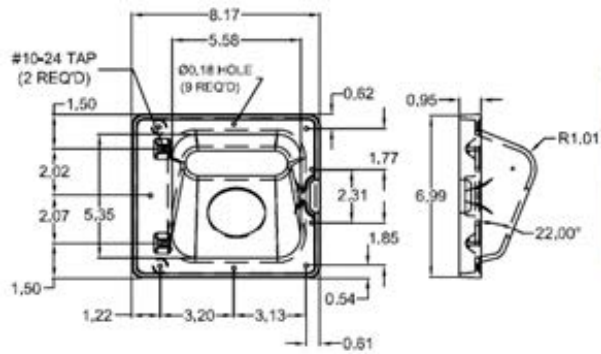

- 1) Finish: Flange is polished. Inside is bead-blasted. Lid is 120 grit directional ground.
- 2) Angle: 21°
- 3) Customer please specify when ordering: 2 1/4", 2 1/2", 2 5/8" hole diameter size.
- 4) All concealed hinges and mounting hardware.

## FG2205

## FG2205 Gas Fill Guard 22° Angle

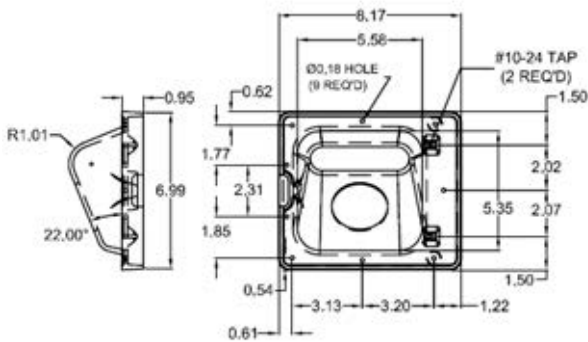

- 1) Finish: Flange is polished. Inside is bead-blasted. Lid is 120 grit directional ground.
- 2) Angle: 21°
- 3) Customer please specify when ordering: 2 1/4", 2 1/2", 2 5/8" hole diameter size.
- 4) All concealed hinges and mounting hardware.

FG2206



## FG2206 Gas Fill Guard (22° Angle) with Lid

- 1) Finish: Guard is wheel-a-brated. Flange is polished. Lid is 120 grit directional ground.
- 2) Customer please specify when ordering: 2 1/4", 2 1/2", or 2 5/8" hole size.
- 3) Angle: 22°
- 4) Use with ADC0028 Access Flange to keep the same appearance as the O<sub>2</sub> Bottle doors.

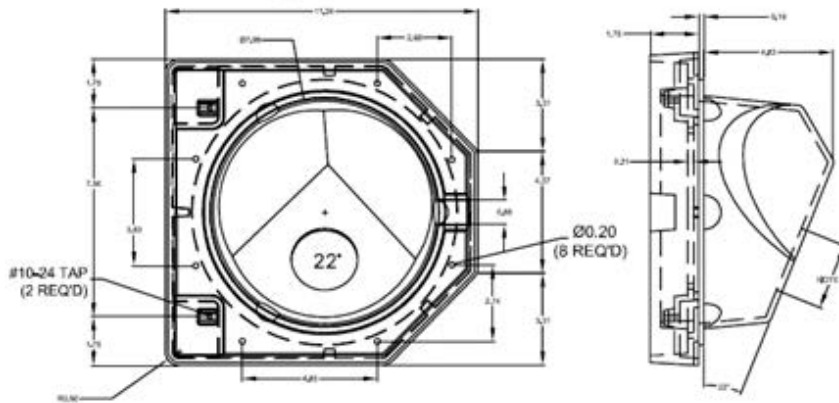

## FG2207

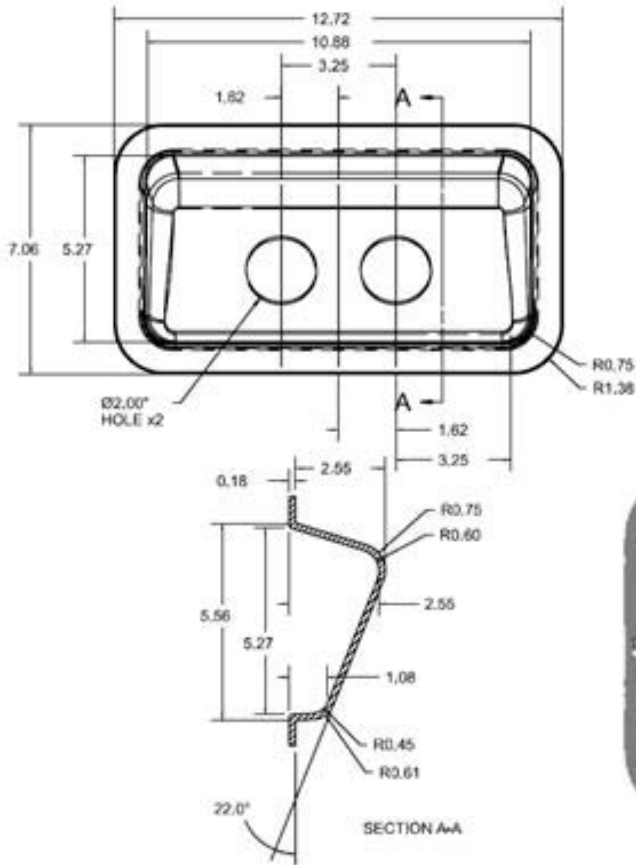

## FG2207 Fuel Filler Guard 22° Angle

- 1) Finish: Flange polished. Inside is ball-burnished.
- 2) Angle: 22°
- 3) Std. with no holes. -A option for dual 2" holes.

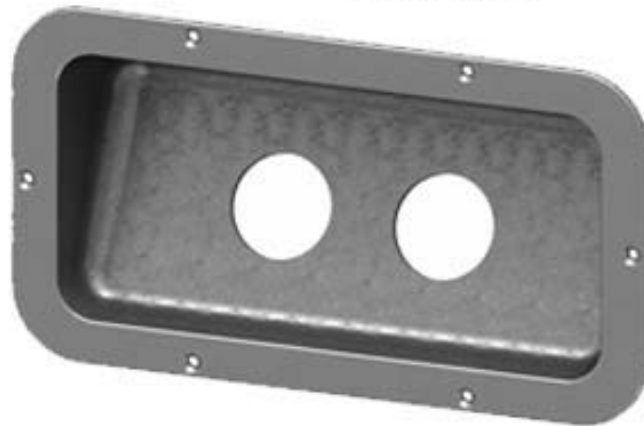

## FG2208

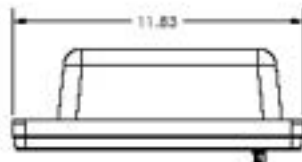
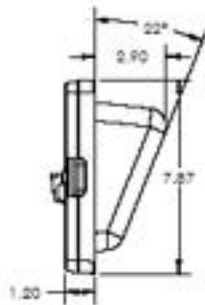

## FG2208 Dual Fuel Filler Guard (22° Angle, 2.50" & 1.75" Holes) w/ Southco 200 Series "Lift & Turn" Latch for 2011 Ford F Series SD

- 1) Finish: Ball-burnished w/ exterior flange polished and lid face 120 grit ground.
- 2) Angle is 22°
- 3) 2.50" & 1.75" diameter cutouts



## FG3001

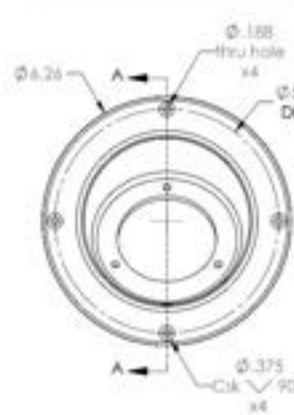

## FG3001 Fuel Filler Cup Casting 30d.

1) Finish: Flange is polished. Interior is wheel-a-brated.

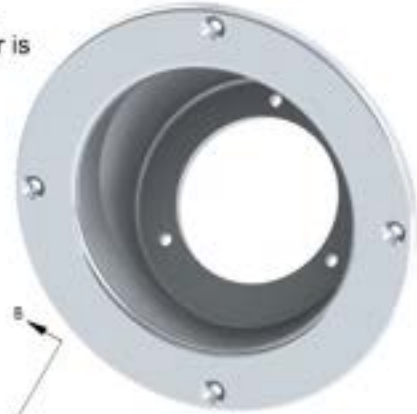
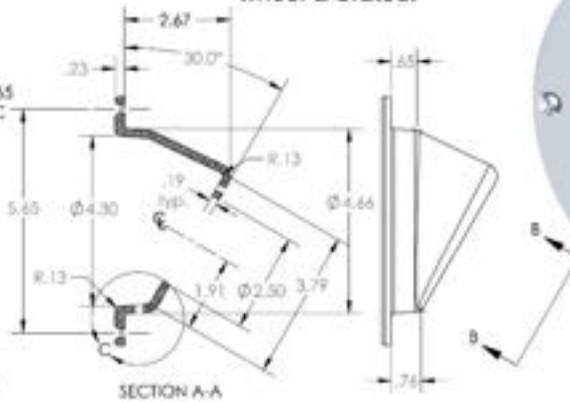

## FG3101

## FG3101 Gas Fill Guard 31° Angle

- 1) Finish: Flange is polished. Inside is Bead-blasted.
- 2) Angle: 31°
- 3) Customer please specify when ordering: 2 1/4", 2 1/2", 2 5/8" hole diameter size.

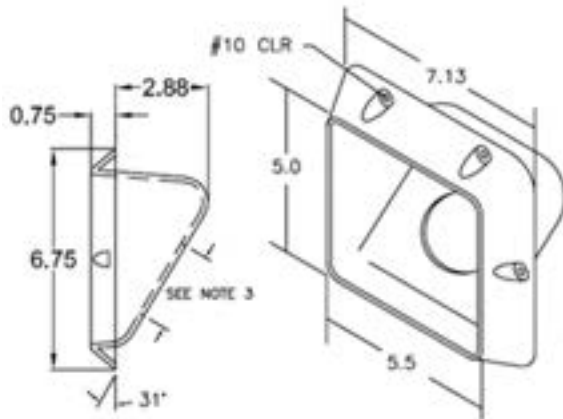

## FG4101

## FG4101 Gas Fill Guard (41° Angle) with Lid

- 1) Finish: Flange is polished. Inside is Bead-blasted. Lid is 120 grit directional ground.
- 2) Angle: 41°
- 3) Customer please specify when ordering: 2 1/4", 2 1/2", or 2 5/8" hole diameter size.
- 4) All concealed hinges and mounting hardware.

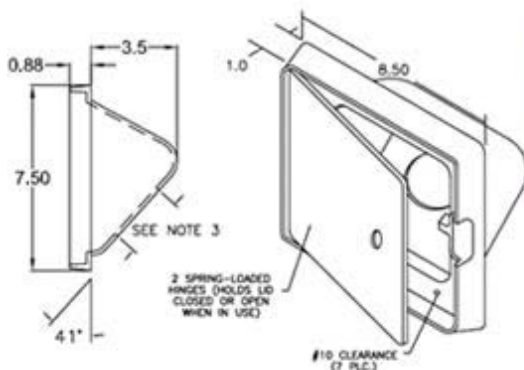

## FG4102

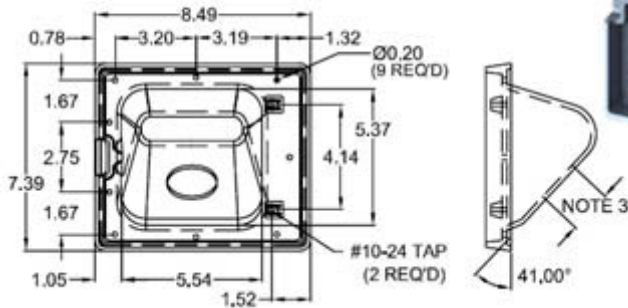

## FG4102 Gas Fill Guard (41° Angle) with Lid

- 1) Finish: Flange is polished. Inside is Bead-blasted. Lid is 120 grit directional ground.
- 2) Angle: 41°
- 3) Customer please specify when ordering: 2 1/4", 2 1/2", or 2 5/8" hole diameter size.
- 4) All concealed hinges and mounting hardware.

## FG4103

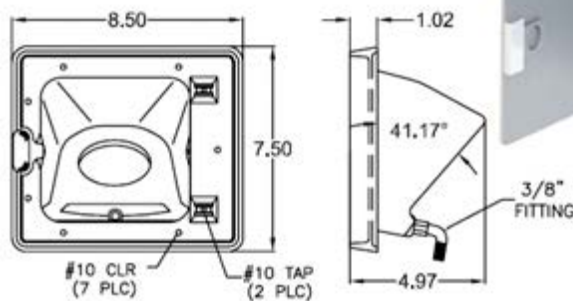

## FG4103 Gas Fill Guard (41° Angle) with Lid

- 1) Finish: Flange is polished. Inside is Bead-blasted. Lid is 120 grit directional ground.
- 2) Angle: 41°
- 3) Customer please specify when ordering: 2 1/4", 2 1/2", 2 5/8" hole diameter size.
- 4) All concealed hinges and mounting hardware and "*spill sump*" included.

## FG4104

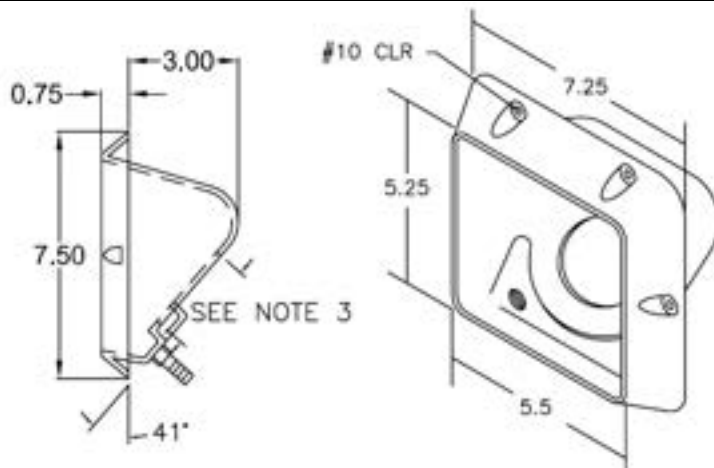

## FG4104 Gas Fill Guard 41° Angle

- 1) Finish: Flange is polished. Inside is Bead-blasted.
- 2) Angle: 41°
- 3) Customer please specify when ordering: 2 1/4", 2 1/2", 2 5/8" hole diameter size.
- 4) "*Spill sump*" uses fuel resistant nylon fitting (provided).

## FG4201

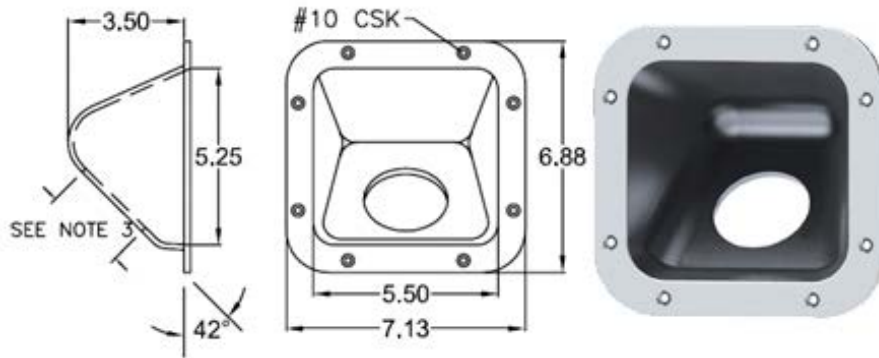

## FG4201 Gas Fill Guard 42° Angle

- 1) Finish: Flange is polished. Inside is Bead-blasted.
- 2) Angle: 42°
- 3) Customer please specify when ordering 2 1/4", 2 1/2", or 2 5/8" hole diameter size.

## FG4202

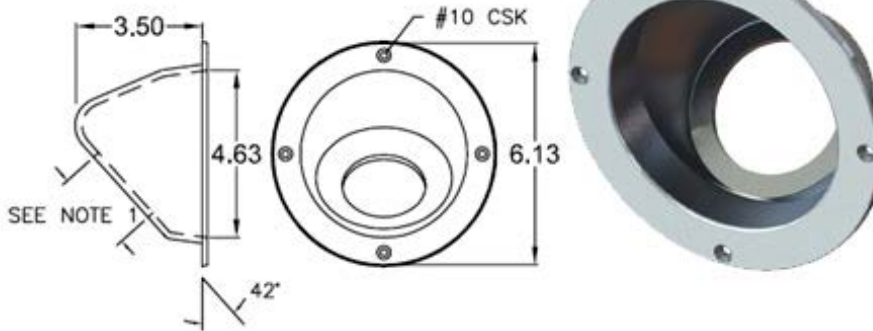

## FG4202 Gas Fill Guard 42° Angle

- 1) Finish: Flange is polished. Inside is Bead-blasted.
- 2) Angle: 42°
- 3) Customer please specify when ordering 2 1/4", 2 1/2", or 2 5/8" hole diameter size.

FG4204

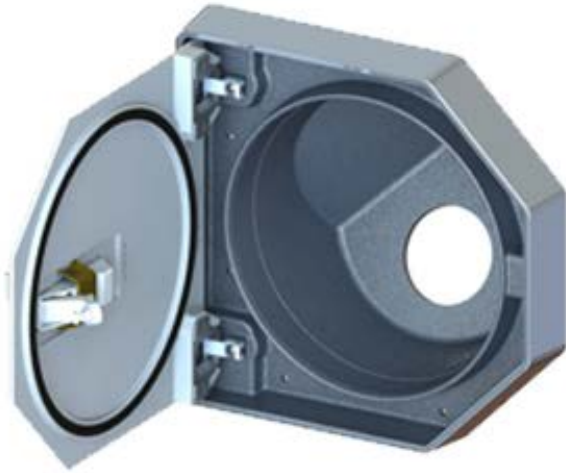

## FG4204 Gas Fill Guard (42° Angle) with Lid

1) Finish: Guard is wheel-a-brated. Flange is polished. Lid is 120 grit directional ground.

2) Customer please specify when ordering: 2 1/4", 2 1/2", or 2 5/8" hole size.

3) Angle: 42°

4) Use with ADC0028 Access Flange to keep the same appearance as the O<sub>2</sub> Bottle doors.

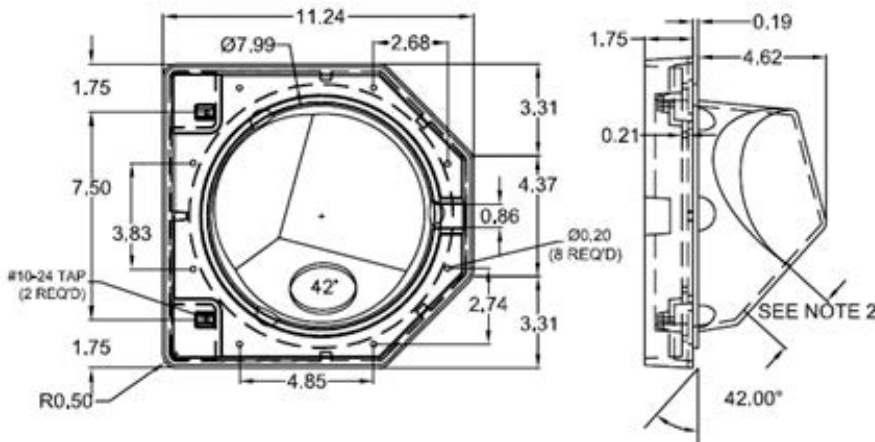

FG4205



## FG4205 Stainless Fuel Filler, 4d., Door Flange, Lid and Plastic Injected Fuel Filler.

- 1) All concealed mounting hardware. Stainless Piano Hinge.
- 2) Thick Rubber Gasket for sealing Flange to Lid. Rubber Gasket for mounting to rear of Plastic Injected Fuel Filler.
- 3) Multiple rear hole options available.
- 4) Fuel Sump area and Nylon Drain Fitting built in.
- 5) 3/4" Keyed Cylinder Latch



Options:  
Lid: Brushed or  
polished finish.

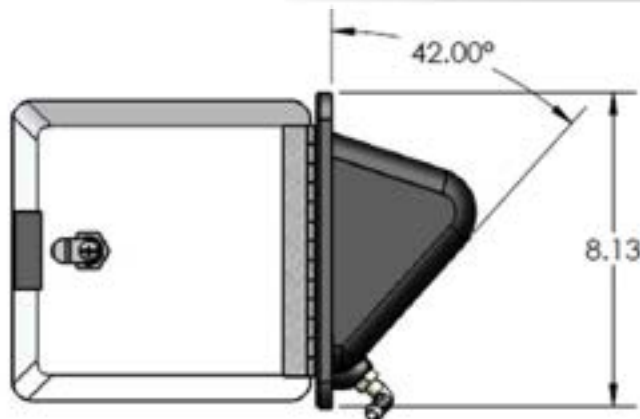

## FG4501

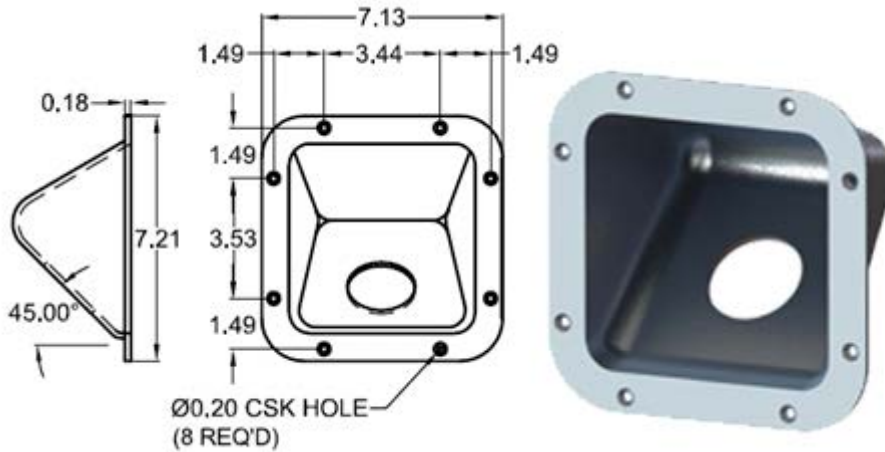

## FG4501 Gas Fill Guard 45° Angle

- 1) Finish: Flange is polished. Inside is Bead-blasted.
- 2) Angle: 45°
- 3) Customer please specify when ordering 2 1/4", 2 1/2", or 2 5/8" hole diameter size.

## FG4502



## FG4502 Fuel (or Urea) Filler Guard (45° Angle)

- 1) Finish: Ball-burnished w/ exterior flange polished.
- 2) Angle is 45°
- 3) For Urea Filler Necks\*  
1 5/8" center hole with four .220" holes or -A version with 1 5/8" center hole and three .250" holes.

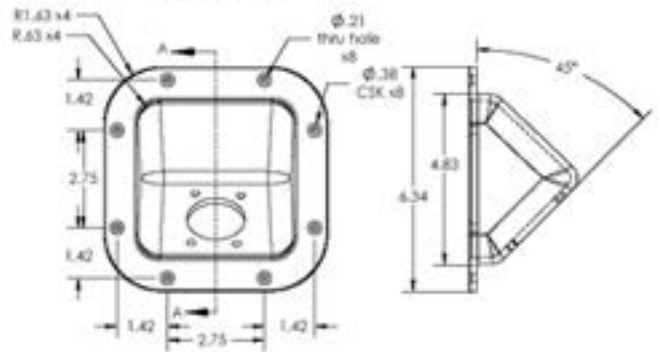

# FG4503



## FG4503 Fuel (or Urea) Filler Guard (45° Angle)

- 1) Finish: Ball-burnished w/ exterior flange polished.
- 2) Angle is 45°
- 3) For Urea Filler Necks\*  
1 5/8" center hole with four .220" holes or -A version with 1 5/8" center hole and three .250" holes.

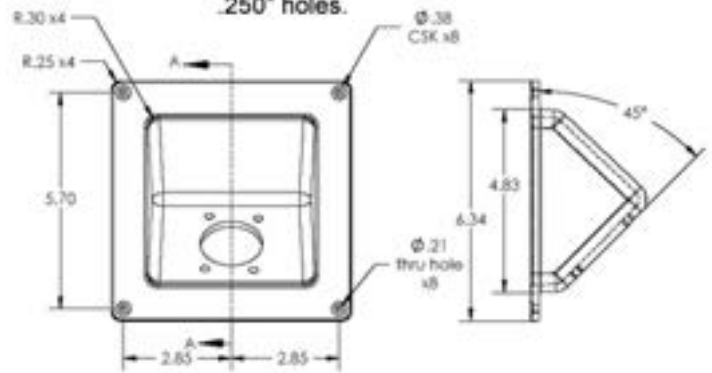

# FG4504

## FG4504 45d. Fuel Filler Guard Casting

1. Finish: Polished exterior flange (-1)  
with wheel-a-brated interior (-4).

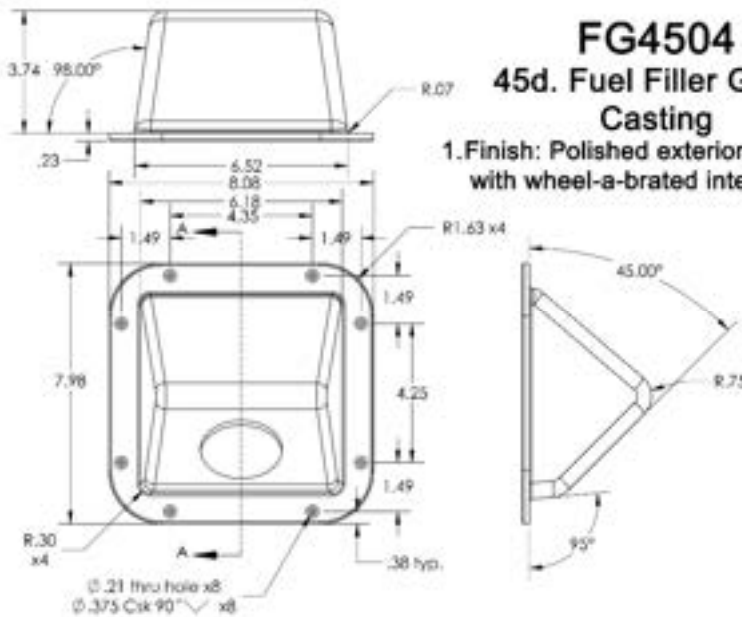

## FG5301

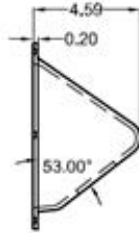
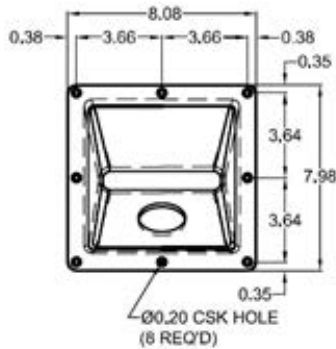

## FG5301 Gas Fill Guard 53° Angle

- 1) Finish: Flange is polished. Inside is Bead-blasted.
- 2) Angle: 53°
- 3) Customer please specify when ordering 2 1/4", 2 1/2", or 2 5/8" hole diameter size.

## FG5302

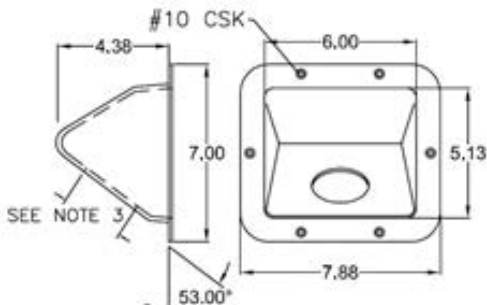

## FG5302 Gas Fill Guard 53° Angle

- 1) Finish: Flange is polished. Inside is Bead-blasted.
- 2) Angle: 53°
- 3) Customer please specify when ordering 2 1/4", 2 1/2", or 2 5/8" hole diameter size.

## FG5303

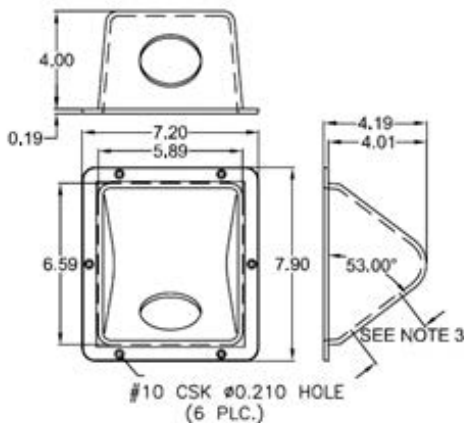

## FG5303 Gas Fill Guard 53° Angle

- 1) Finish: Flange is polished. Inside is Bead-blasted.
- 2) Angle: 53°
- 3) Customer please specify when ordering 2 1/4", 2 1/2", or 2 5/8" hole diameter size.

## FG5304

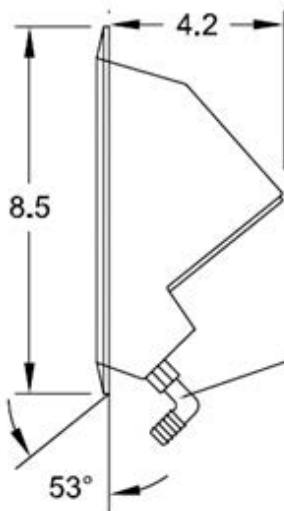
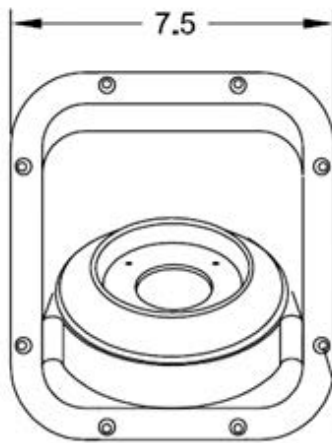

## FG5304 "Break-Away" Gas Fill Guard with Spill Sump

- 1) "**Break-Away**" Design incorporates a rubber gasket insert that permits fuel fill neck to separate from insert or insert separate from casting in the event of vehicle roll or module body separation, increasing chances of leaving fuel fill neck intact with fuel tank.
- 2) Casting "**spill sump**" uses fuel resistant nylon fitting (provided) to use with 3/8" flexible hose to route spilled fuel away and to the ground.
- 3) Aluminum ring to bolt rubber insert against fuel fill neck backplate. Rubber stretches to seal around various size fuel fill necks.
- 4) Finish: Flange is polished. Inside is Bead-blasted.
- 5) Angle: 53°.

## FG5305

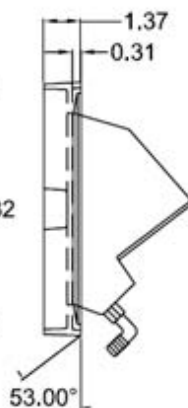
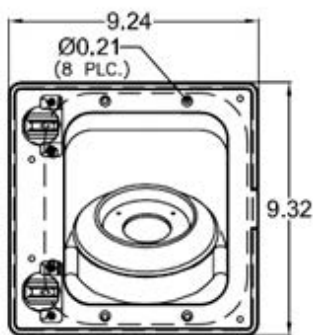

## FG5305 Gas Fill Guard (53° Angle) with Lid

- 1) Finish: Flange is polished. Inside is bead-blasted. Lid is 120 grit directional ground.
- 2) Angle: 53°
- 3) All concealed hinges and mounting hardware.
- 4) "**Break-Away**" and "**spill sump**" design.

## FG5306

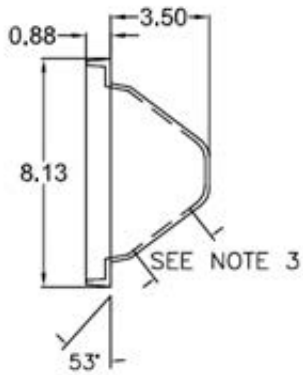

## FG5306 Gas Fill Guard (53° Angle) with Lid

- 1) Finish: Flange is polished. Inside is bead-blasted. Lid is 120 grit directional ground.
- 2) Angle: 53°
- 3) Customer please specify when ordering: 2 1/4", 2 1/2", or 2 5/8" hole diameter size.
- 4) All concealed hinges and mounting hardware.

## FG5307

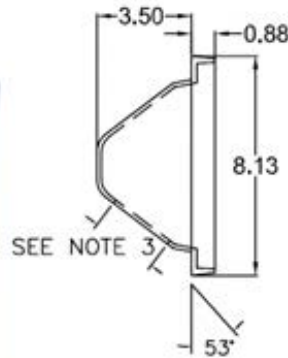
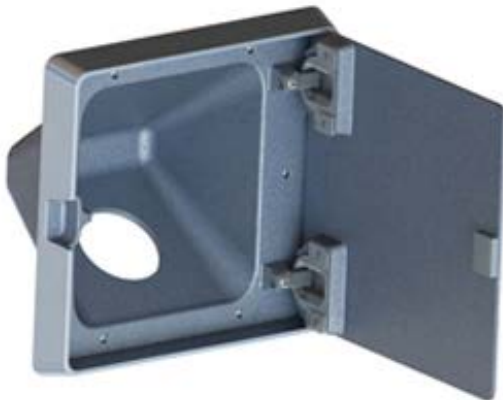

## FG5307 Gas Fill Guard (53° Angle) with Lid

- 1) Finish: Flange is polished. Inside is bead-blasted. Lid is 120 grit directional ground.
- 2) Angle: 53°
- 3) Customer please specify when ordering: 2 1/4", 2 1/2", or 2 5/8" hole diameter size.
- 4) All concealed hinges and mounting hardware.

## FG5308

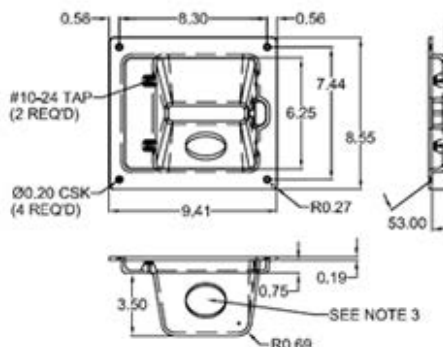

## FG5308 Recessed Gas Fill Guard (53° Angle) with Lid

- 1) Finish: Flange is polished. Inside is bead-blasted. Lid is 120 grit directional ground.
- 2) Angle: 53°
- 3) Customer please specify when ordering: 2 1/4", 2 1/2", or 2 5/8" hole diameter size.
- 4) All concealed hinges and mounting hardware.

## FG5309

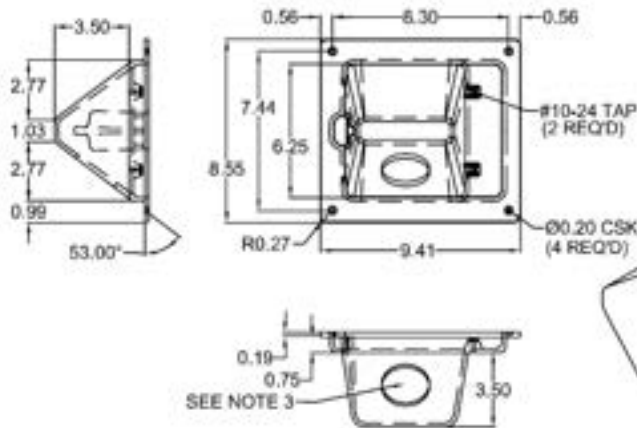

## FG5309

### Recessed Gas Fill Guard (53° Angle) with Lid

- 1) Finish: Flange is polished. Inside is bead-blasted. Lid is 120 grit directional ground.
- 2) Angle: 53°
- 3) Customer please specify when ordering: 2 1/4", 2 1/2", or 2 5/8" hole diameter size.
- 4) All concealed hinges and mounting hardware.

## FG5310

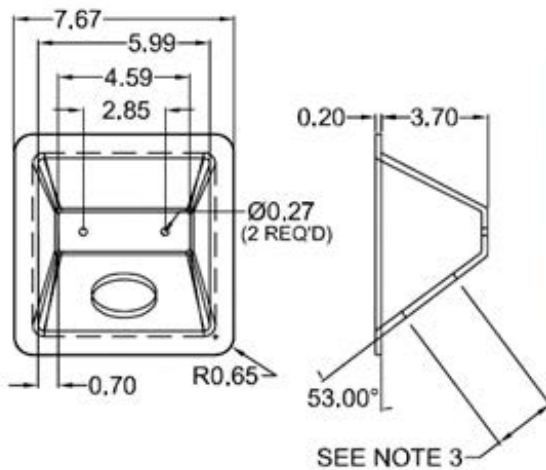

## FG5310 Gas Fill Guard 53° Angle

- 1) Finish: Flange is polished. Inside is bead-blasted.
- 2) Angle: 53°
- 3) Customer please specify when ordering: 2 1/4", 2 1/2", or 2 5/8" hole diameter size.

## FG5501

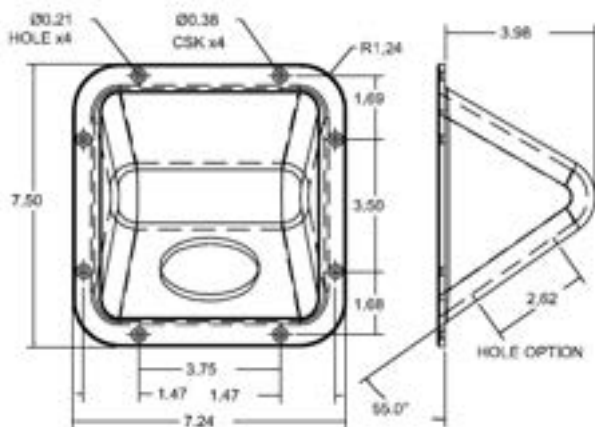

## FG5501 Gas Fill Guard (55° Angle)

- 1) Finish: Flange is polished. Inside is bead-blasted.
- 2) Customer please specify when ordering: 2 1/4", 2 1/2", or 2 5/8" hole size.
- 3) Angle: 55°

## FG5502

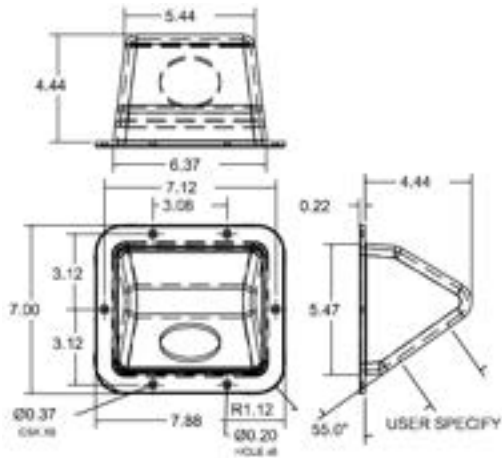

## FG5502 Gas Fill Guard (55° Angle)

- 1) Finish: Flange is polished, Inside is bead-blasted.
- 2) Customer please specify when ordering: 2 1/4", 2 1/2", or 2 5/8" hole size.
- 3) Angle: 55°

## FG5503

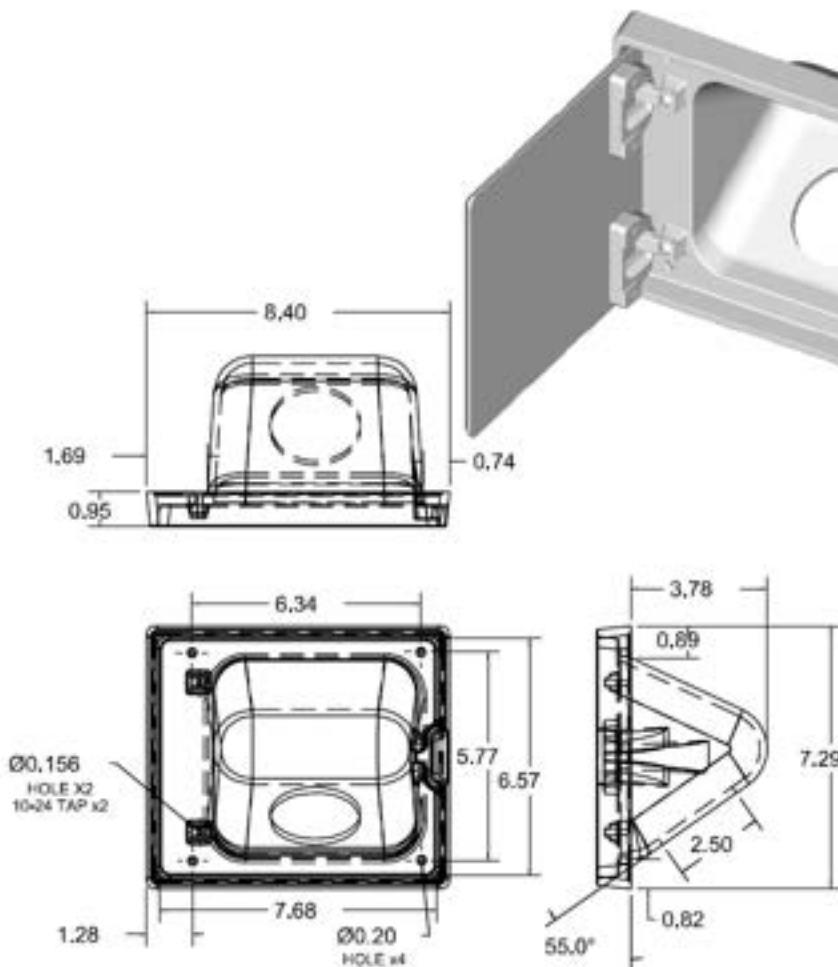

## FG5503 Gas Fill Guard (55° Angle) with Lid

- 1) Finish: Flange is polished, Inside is bead-blasted, Lid is 120 grit directional ground.
- 2) Customer please specify when ordering: 2 1/4", 2 1/2", or 2 5/8" hole size.
- 3) Angle: 55°
- 4) All concealed hinges and mounting hardware

## FG5504

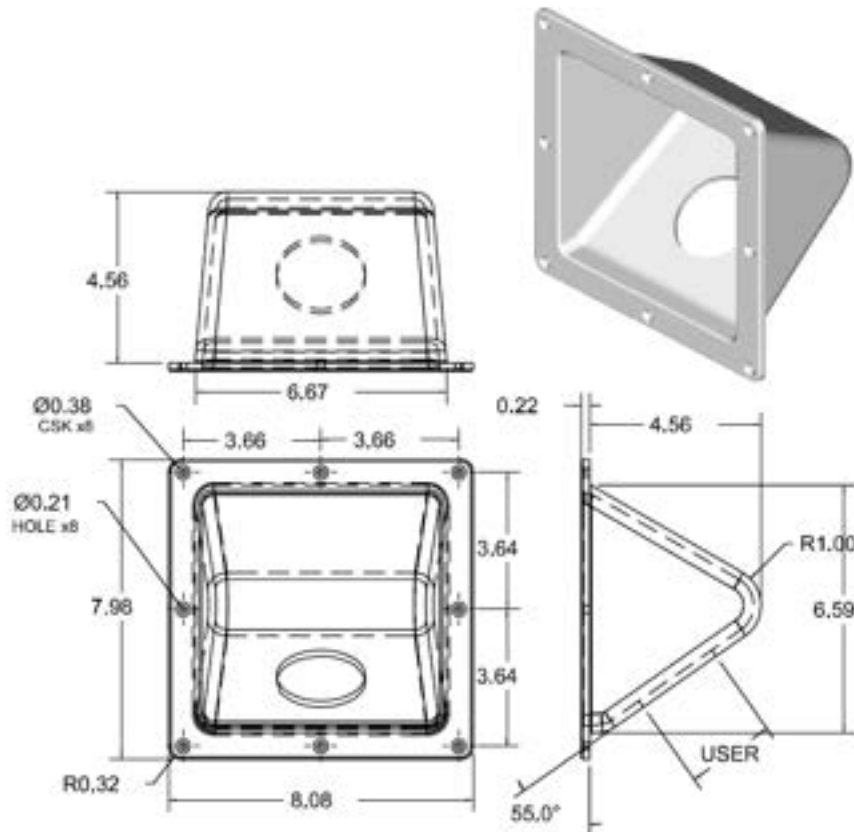

## FG5504 Gas Fill Guard (55° Angle)

- 1) Finish: Flange is polished. Inside is bead-blasted.
- 2) Customer please specify when ordering: 2 1/4", 2 1/2", or 2 5/8" hole size.
- 3) Angle: 55°

## FG5701

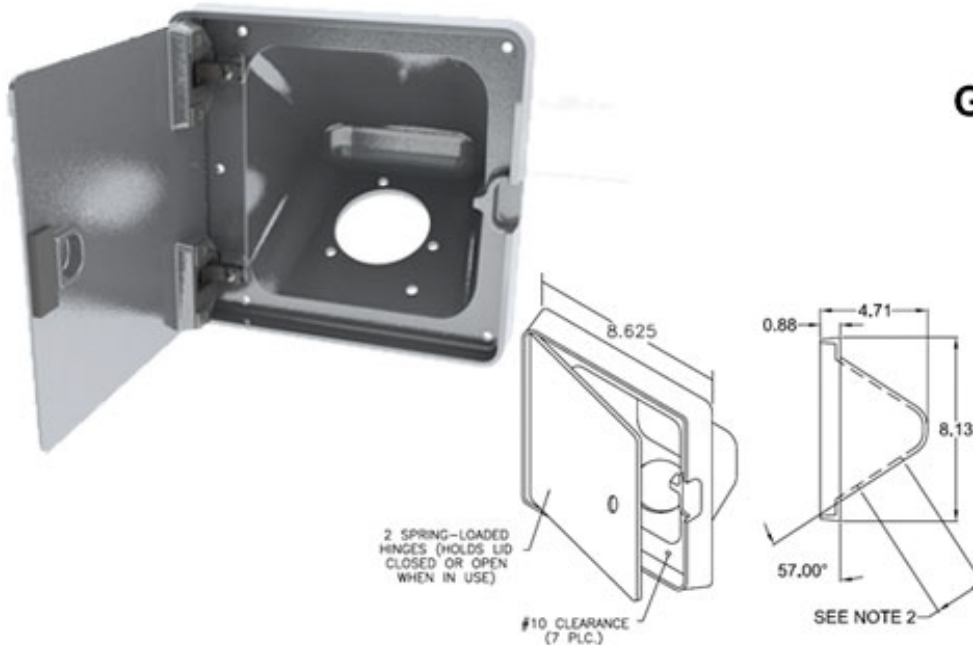

## FG5701 Gas Fill Guard (57° Angle) with Lid

- 1) Finish: Flange is polished. Inside is bead-blasted. Lid is 120 grit directional ground.
- 2) Customer please specify when ordering: 2 1/4", 2 1/2", or 2 5/8" hole size.
- 3) Angle: 57°
- 4) All concealed hinges and mounting hardware

**FG5703**



# **FG5703**

## **Gas Fill Guard**

### **57° Angle**

- 1) Finish: Flange is polished. Inside is bead-blasted.
- 2) Customer please specify when ordering: 2 1/4", 2 1/2", or 2 5/8" hole size.
- 3) Angle: 57°

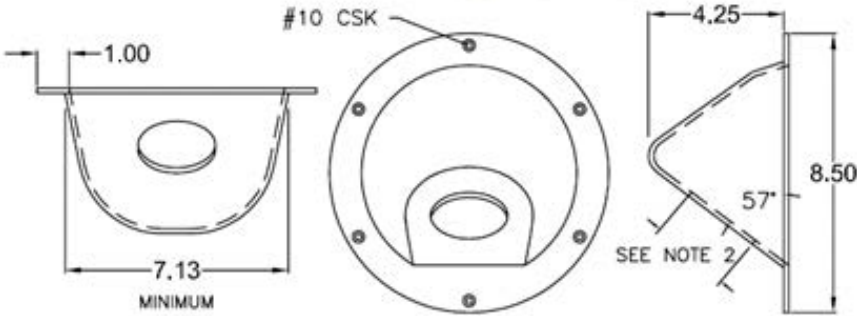

**FG5704**



## FG5704 Gas Fill Guard 57° Angle

- 1) Finish: all exterior surfaces are polished. Inside is ball-burnished.
- 2) Angle: 57°
- 3) Standard with 2 1/2" hole and additional neck mounting holes.

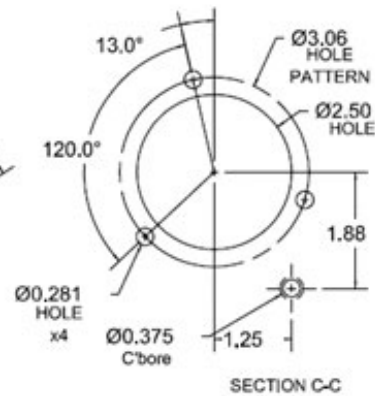
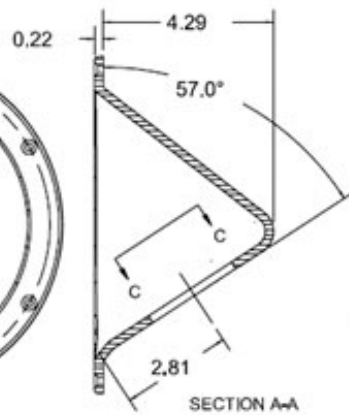
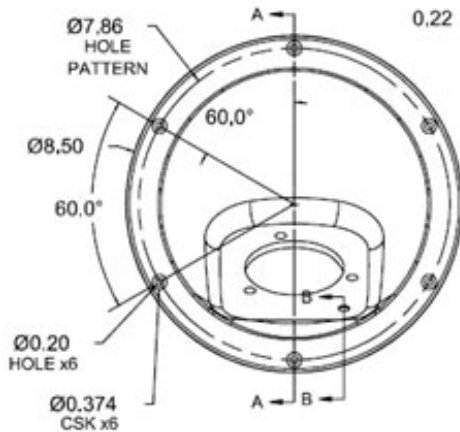
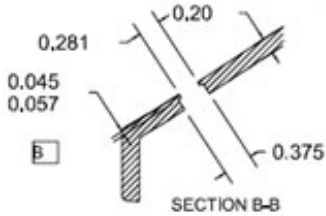

**FG6501**



## FG6501 Gas Fill Guard 65° Angle

- 1) Finish: all exterior surfaces are polished. Inside is ball-burnished.
- 2) Angle: 65°
- 3) Customer specify hole size desired: 2", 2 1/4", 2 3/8", 2 1/2" or 2 5/8".

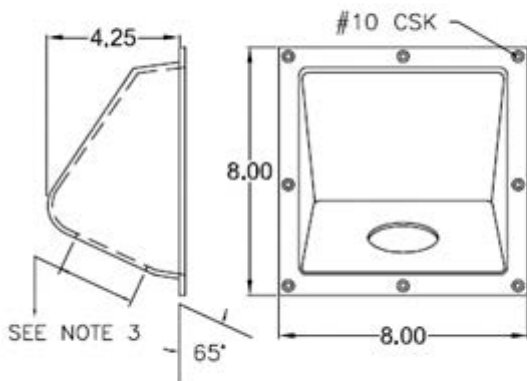

FGL0022 FGL0042 FGL0053

### FGL0022 FGL0042 FGL0053

Fuel Filler Guard, Rear  
neck hole w/ Lid, with  
Latch, Flange, Sump and  
90d. Nylon Fitting

- 1) Finish: interior is ball-burnished with mounting flange polished. Lid is 120 grit directional ground.
- 2) Can be supplied with Southco Lift-n-Turn lever latch or without latch
- 3) Features sump area and 90d. nylon fitting for drain. Standard lid and mounting flange used different angled backs.
- 4) Specify rear hole diameter or options.

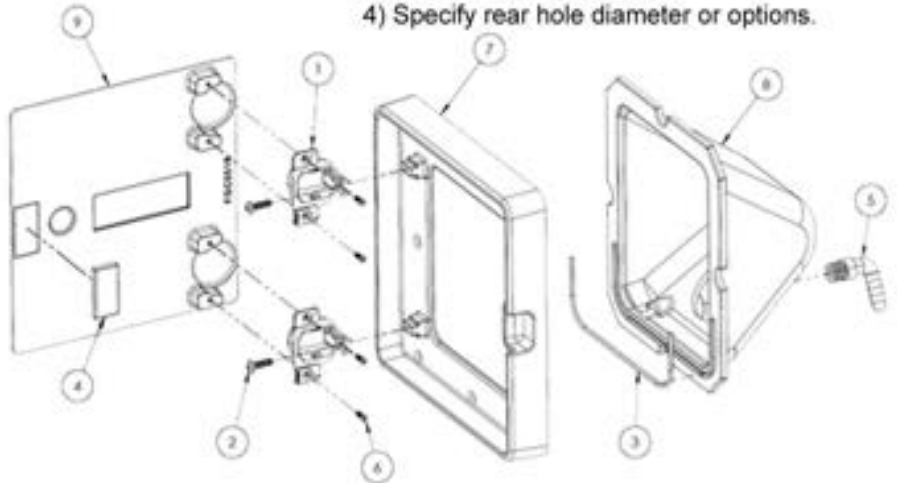

FGT0022 FGT0042 FGT0053

**FGT0022 FGT0042  
FGT0053**

**Fuel Filler Guard, Rear  
neck hole with Face  
Trim, Sump and 90d.  
Nylon Fitting**

- 1) Finish: interior is ball-burnished with polished Trim Flange.
- 2) Features sump area and 90d. nylon fitting for drain. Standard Face Trim uses different angled backs.
- 4) Specify rear hole diameter or options.

